

**REVO<sup>®</sup>-E Heat pump  
Volvo**

**Workshop Manual**

## 1 Introduction

1.1	Content and purpose	101
1.2	Validity of the workshop manual	101
1.3	Meaning of emphasis	101
1.4	Symbols	101
1.5	Additional documentation to be used	101
1.6	Safety information and condition	101
1.6.1	General safety information	102
1.6.2	Working with high-voltage air-conditioning systems	102
1.6.3	Working with refrigerants	102
1.6.4	Working with pressurized containers	103
1.6.5	Technical rules for pressurized gases (TRG)	103
1.6.6	Waste and residual materials	103
1.7	Suggestions for improvement and change	103
1.8	Abbreviations	104

## 2 Technical specifications

### 3 Description of assemblies and components

3.1	REVO-E HP versions on the Volvo 79xx Electric	301
3.2	Total overview of the design and components of the REVO-E heat pump	302
3.3	Overview of high-voltage cable harnesses / components (400V AC / 600V DC)	303
3.4	Cable harnesses overview (high-voltage / low-voltage) in the REVO-E HP	304
3.5	Design / task and function of the assemblies	305

### 4 Function and functional schematics of the REVO-E Heat pump

4.1	General function	401
4.2	Functional schematic of the REVO-E heat pump	402
4.3	Functional schematic of the REVO-E heat pump Volvo 7900 Electric	403
4.4	Work modes of the REVO-E heat pump in the Volvo 7900 Electric	404
4.4.1	Heating and Ventilation Mode (HV Mode)	405
4.4.2	Heating and Ventilation Mode Ready for cooling	406
4.4.3	Heating and Ventilation Mode Ready for Heat Pump Mode	407
4.4.4	Cooling Mode	408
4.4.5	Heat Pump Mode	410
4.4.6	Operating Mode De-Icing) (Version HP+ only)	412
4.4.7	Operating Mode Oil Recovering (Version HP+ only)	413
4.4.8	Reheat Mode	414
4.4.9	Waste Energy Mode	415
4.4.10	Gas Charging Mode	416
4.5	Refrigerant circuit function schematic of the heat pump	417
4.5.1	Refrigerant circuit function schematic of the heat pump in the Cooling Mode	418
4.5.2	Refrigerant circuit function schematic of the heat pump in the Heat Pump Mode	419
4.5.3	4-way reversing valve function schematic	420
4.5.4	Refrigerant circuit function schematic of the heat pump with hot gas de-icing (11123865_ only)	422

### 5 Troubleshooting

5.1	General	501
5.2	Malfunctions in the air-conditioning circuit	501
5.2.1	Causes of malfunctions in the air-conditioning system	501
5.2.2	What to do for malfunctions in the refrigerant circuit	501
5.2.3	Why the desired conditions are not reached when testing pressure	501

5.3	Malfunctions in the electrical system	501
5.4	Table of error codes	503
5.5	Error codes	504
5.6	Inspecting functionality of individual components	509
5.6.1	General visual inspection	509
5.7	Diagnosing the REVO-E units using the Diagnosis Control Test – DCT diagnostic software	509
5.8	Diagnosing the frequency converter	509
<b>6</b>	<b>Wiring diagrams</b>	
6.1	Electrical fuses	601
6.2	Wiring diagram REVO-E HP (11120816*)	601
6.3	Wiring diagram REVO-E HP+ (11123865*)	608
6.4	Frequency converter - electrical connections	615
6.4.1	600V DC power supply including HVIL connector	615
6.4.2	400V AC voltage output	616
6.4.3	PE connection (potential equalizing)	616
6.5	Compressor - electrical connections	617
6.5.1	400V AC voltage supply	617
6.5.2	PE connection (potential equalizing)	617
<b>7</b>	<b>Maintenance</b>	
7.1	Safety information	701
7.2	Versions of ADA	701
7.3	Maintenance and upkeep	701
7.4	Inspection and maintenance	701
7.4.1	Changing the fresh air filter	701
7.4.2	Changing the filter dryer	701
7.4.3	Inspecting the oil level of the compressor	702
7.4.4	Changing the compressor oil	702
<b>8</b>	<b>Removal and installation of components (high-voltage system)</b>	
8.1	Safety information	801
8.2	Versions of ADA	801
8.3	Preparation/follow-up	801
8.3.1	High-voltage system	801
8.3.2	Refrigeration section	801
8.4	Frequency converter removal/ installation	802
8.4.1	Remove the frequency converter	802
8.3.2	Install the frequency converter	803
8.4	Refrigerant compressor removal/ installation	804
8.4.1	Remove the compressor	804
8.4.2	Comparing the old/new oil level	806
8.4.3	Install the compressor	806
8.5	600V DC/ 400V AC high-voltage cable removal/ installation	808
8.5.1	Remove the 600V AC cable	808
8.5.2	Install the 600V DC cable	808
8.5.3	Remove the 400V AC cable	808
8.5.4	Install the 400V AC cable	809
<b>9</b>	<b>Removal and installation of components</b>	
9.1	Safety information	901
9.2	Versions of ADA	901
9.3	Preparation/follow-up	901
9.4	Condenser module removal/ installation	901

9.4.1	Removal of the condenser module	901
9.3.2	Installation of the condenser module	902
9.4	Expansion valves removal/ installation	903
9.4.1	Positions of the expansion valves and the associated contact sensors	903
9.4.2	Remove an expansion valve	904
9.4.3	Install an expansion valve	904
9.5	Filter dryer removal/ installation	905
9.5.1	Remove the filter dryer	905
9.5.2	Install the filter dryer	905
9.6	Receiver removal/ installation	905
9.6.1	Remove the receiver	905
9.6.2	Install the receiver	905
9.7	Double radial blowers / axial fans removal/ installation	906
9.7.1	Remove a double radial blower	906
9.7.2	Install a double radial blower	906
9.7.3	Remove an axial fan	906
9.7.4	Install an axial fan	906
9.8	Recirculating air flap actuator motor removal/ installation	907
9.8.1	Remove the actuator motor	907
9.8.2	Install the actuator motor	907
9.9	Temperature sensor (duct / recirculating air suction) removal/ installation	907
9.9.1	Remove the duct temperature sensor (blow-out temperature)	907
9.9.2	Install the duct temperature sensor (blow-out temperature)	907
9.9.3	Remove the recirculating air suction temperature sensor (passenger compartment)	907
9.9.4	Install the recirculating air suction temperature sensor (passenger compartment)	907
9.10	Suction pressure sensor removal/ installation	908
9.10.1	Remove the suction pressure sensor	908
9.10.2	Install the suction pressure sensor	908
9.11	High-pressure sensor removal/ installation	908
9.11.1	Remove the high-pressure sensor	908
9.11.2	Install the high-pressure sensor	908
9.12	Pressure switch removal/ installation	909
9.12.1	Remove the pressure switch	909
9.12.2	Install the pressure switch	909
9.13	Compressor suction and pressure lines removal/ installation	909
9.13.1	Remove the pressure line	909
9.13.2	Install the pressure line	909
9.13.3	Remove the suction line	909
9.13.4	Install the suction line	909
9.14	Solenoid valve removal/ installation	910
9.14.1	Remove the coil	910
9.14.2	Install the coil	910
9.14.3	Remove the screw-in valve	910
9.14.4	Install the screw-in valve	910

## Attachment A

Torque values/ seales

A-1

# 1 Introduction

## 1.1 Content and purpose

This workshop handbook is for repairs and maintenance purposes of the rooftop system (subsequently referred to as air-conditioning system) REVO-E.

 <b>Warning!</b>	<b>Potential risk to health and life!</b>
---	---

Work on the air-conditioning system is only to be conducted by personnel who are qualified pursuant to DGUV Information 200-005 (old BGI 8686) or, outside of the German market, by personnel who are instructed/trained according to corresponding local regulations.

The required qualifications differ depending on the content and scope of the work on the air-conditioning system. See point 1.6.1 below.

## 1.2 Validity of the workshop manual

This workshop manual is valid for all of the air-conditioning systems listed on the cover page. It may be subject to changes and addenda. The currently valid version is binding. These are found on the Valeo homepage in the Service / Downloads area.

## 1.3 Meaning of emphasis

In this handbook, the emphases of Warning!, Caution!, ATTENTION: and NOTE: mean the following:

 <b>Warning!</b>	<b>Potential risk to health and life!</b>
---	---

This heading is used when improperly following or not following instructions or processes can lead to serious injuries or fatal accidents.

 <b>Caution!</b>	<b>Hazardous to health!</b>
---	-----------------------------

This heading is used when improperly following or not following instructions or processes can lead to minor injuries.

### ATTENTION:

Indicates procedures which may lead to material damage.

### NOTE:

Is used when something is to be emphasized.

## 1.4 Symbols



Symbol of tightening torque: Used in graphics, indicates parts (e.g. lock nuts, screws) that must be attached with a certain tightening torque. The values of the tightening torque are found in the torque table in Attachment A and are binding.

## 1.5 Additional documentation to be used

The use of additional servicing literature is required. This is indicated in the workshop manual in the corresponding location.

Use the following documents when operating and servicing the air-conditioning system:

- Installation instructions for the REVO-E
- Evacuation and filling instructions for the REVO-E
- Maintenance and service plan for the REVO-E
- Spare parts list for the REVO-E Heat pump
- Technical information (TI)

This servicing literature is also available for download at [www.valeo-thermalbus.com/eu\\_en/Service/Downloads/Air-Conditioning](http://www.valeo-thermalbus.com/eu_en/Service/Downloads/Air-Conditioning).

## 1.6 Safety information and condition

The air-conditioning system was designed and produced according to EC directives. The system is safe to operate if properly installed and used in accordance with the installation, operation and servicing instruction.

Nonobservance of the servicing literature listed under 1.5 and the instructions included within excludes Valeo from liability.

Always observe the general accident prevention regulations. The “general safety conditions” beyond the framework of these regulations are listed below.

1.6.1 General safety information

Required qualifications

 <b>Warning!</b>	High voltage! Caution Mortal danger!
---	--

To work on the refrigeration section of the air-conditioning system, proof of both of the following qualifications is required:

- electrically qualified person (EQP)  
 EQP: Trained in non-electrical work on/near high-voltage systems, knows the dangers, does not work independently (supervision and controls), trained according to DGUV 200-005 (old BGI 8686)
- Specialists trained in refrigeration technology with certificate of competence pursuant to Directive (EC) no. 307/2008

To work on the high-voltage section of the air-conditioning system, proof of both of the following qualifications is required:

- Electrician for HV systems in powered vehicles Vocational education, job of repeating character, training pursuant to DGUV 200-005 (old BGI 8686)
- Specialists trained in refrigeration technology with certificate of competence pursuant to Directive (EC) no. 307/2008

**NOTE:**

The conditions of these rules are valid within the jurisdiction of DGUV (German Social Accident Insurance) and must be followed even in countries without special provisions.

Know and follow the operating and servicing instruction for the systems, tools and aids used as well as their accompanying safety information from the manufacturer when evacuating and filling the air-conditioning system.

Working on the bus roof

 <b>Warning!</b>	Danger of serious injury or death by falling!
---	--

When working on the bus roof or hydraulic lifts, scaffolding, etc, take suitable measures to prevent falling.

1.6.2 Working with high-voltage air-conditioning systems

 <b>Warning!</b>	High voltage! Caution Mortal danger!
---	--

Only conduct installation, maintenance and repair work if the motor is still and the 24V DC power supply as well as the high-voltage has been switched off.

Before starting work on the air-conditioning system, ensure that the system is voltage-free and make sure it remains so for the duration of the work.

In certain cases, the following safety rules must be followed:

- make the system voltage-free
- ensure that the system cannot be reactivated
- check whether the system is voltage-free
- ground and short-circuit
- cover or block off neighboring voltage-carrying parts

Electrical work may only commence if protective measures against electrical shock, short-circuits and electric arcs have been taken.

1.6.3 Working with refrigerants

 <b>Caution!</b>	Hazardous to health!
---	----------------------

Observe EN 378 when working on cooling systems. There is an info data sheet or material sheet (available from manufacturer) for each refrigerant as well as the general information from professional organizations within the chemical industry.

Certain conditions apply, that must be maintained, for the safe and proper use of refrigerants:

- Wear protective eye wear when working with refrigerants. If a refrigerant gets into the eye, serious frostbite damage may occur. Thoroughly rinse the eyes with water immediately and seek medical attention.
- Wear protective gloves when working with refrigerants. Liquids refrigerant is not to come into contact with the skin. The hands must be protected from frostbite (leaking R 134a condenses at -26.5°C) and from erosion to the skin's protective layer (refrigerants dissolve fat)! If a refrigerant comes into contact with the skin, thoroughly rinse the point of contact with water immediately and seek medical attention.



- There is a possible risk of suffocation if the refrigerant leaks into the atmosphere. Refrigerants are heavier than air. At and beyond a concentration of approx. 12% in the air, there will not be sufficient oxygen to breathe. Loss of consciousness and increased cardiovascular problems caused by stress and lack of oxygen will result. This is a fatal hazard!
- It is forbidden to smoke when handling refrigerants. A burning cigarette can break the refrigerant down. Poisonous substances will form as a result.
- Before welding and soldering cooling systems, the cooling system must be completely evacuated and any residue removed by blowing in nitrogen. If exposed to heat, refrigerants will release products of decomposition that are not hazardous but can also cause corrosion.
- Nonflammable refrigerants also pose a fire risk via the ignition of displaced oil residue and insulating material as well as the oil mist caused by strong leakages.

#### 1.6.4 Working with pressurized containers



- Ensure that the container does not fall over or roll away
- Do not throw the container. If struck, the containers may be so deformed that they rupture. Considerable forces are let free if the heat exchanger is suddenly struck and refrigerants leak out. The same applies if cylinder valves break. Therefore, the cylinders are only to be transported with protective cap.
- Refrigerant cylinders are not to be kept near heating units. Higher temperatures mean higher pressures, which may lead to the container exceeding its maximum allowed pressure. The rules for pressurized containers stipulate that containers are not to be warmed beyond 50 °C.

- Never warm refrigerant cylinders with an open flame. The material may become damaged from the excessive temperature, resulting in decomposition of the refrigerant.
- Close empty containers to prevent the entry of moisture.
- Never overfill refrigerant cylinders, since an increase in temperature can lead to enormous pressures.

#### 1.6.5 Technical rules for pressurized gases (TRG)

The applicable rules for the manufacturer and workshop are listed in the Technical Rules for Pressurized Gases (TRG). Personnel who conducted maintenance and repair work on the air-conditioning system must know and follow these rules.

#### 1.6.6 Waste and residual materials

The valid legal conditions and regulations, that concern waste disposal as well as how to process residual material, must be followed.

#### Disposing of refrigerant and refrigerator oil

The refrigerants to be disposed of are to be placed into the labeled recycling containers, taking into consideration the present fill level.

Used refrigerator oils from systems with halogenated hydrocarbons must be disposed of as special waste. It is forbidden to mix these with other oils or substances. Follow country-specific guidelines for proper storage and disposal.

#### 1.7 Suggestions for improvement and change

Please refer any complaints, suggestions for improvement or change for this manual to:

**service-valeobus@valeo.com**

## 1.8 Abbreviations

Abbreviations	DE	EN	Description
REVO-E HP			- ident no. 11120816_ - installed on Volvo E Bus 1st Generation - lower operating limit HP $\geq 3^{\circ}\text{C}$
REVO-E HP+			- ident no. 11123865_ - installed on Volvo E Bus 2nd Generation - lower operating limit HP $\geq -5^{\circ}\text{C}$
AC	Klimaanlage	Air Condition	air conditioning only
ADA	Aufdachanlage	Roof Top Unit	
BEA (el.)		Body Electrical Architecture	electronic regulations of the passenger compartment
DCT	Diagnose Control Test	Diagnosis Control Test	previously Spheros Control Test -SCT
EU6	Euro 6	Euro 6	Europe variant
GH		Global Hybrid	global chassis application
HGA	Heißgasabtauung	Hot Gas Deicing	
HV	Hochvolt	High Voltage	
HVAC	Heizen/ Lüften/ Klima	Heating/ Ventilation/ Air-Conditioning	
HVIL	High Voltage Interlock Loop		High voltage interlock loop
i.O. / OK	in Ordnung	in working order	
n.i.O. / NOK	nicht in Ordnung	not in working order	
PE	Potentialausgleich	Potential Equalizing	safety earthing
PTC	positiver Temperaturkoeffizient	Positive Temperature Coefficient	
SC600	ECU REVO-E AC		electronic control unit REVO-E AC (replaced by SC610)
SC610	ECU REVO-E AC		electronic control unit REVO-E AC (replaced by SC610)
SC620	ECU REVO-E WP	ECU REVO-E HP	electronic control unit REVO-E WP
V AC	Wechselspannung	Volts Alternating Current	
V DC	Gleichspannung	Volts Direct Current	
HP	Wärmepumpe	Heat Pump	ADA with heat pump function



## 2 Technical specifications

The technical specifications, provided that there are no limit values given, comply with the standard tolerances for air-conditioning systems of  $\pm 10\%$  for an ambient temperature of  $+20^{\circ}\text{C}$  and nominal voltage.

Table 201 Technical specifications

REVO-E heat pump		REVO-E HP+ 11123865_ <sup>3</sup>	REVO-E HP 11120816_
Application		Volvo E-Bus 2nd Generation (from 2018)	Volvo E-Bus 1st Generation (till 2018)
Operating range heat pump [ $^{\circ}\text{C}$ ]		$\geq -5$	$\geq 3$
Cooling capacity [kW] <sup>1</sup>		25	
Heating capacity in heat-pump-mode [kW] <sup>2</sup>		16	
Heating capacity coolant circuit [kW]		40	
Air volume [ $\text{m}^3/\text{h}$ ]		6960	
Current consumption [A] (24 V DC)	maximum (all 100 %)	85	
	nominal (condenser 80%, evaporator 70%)	55	
	regulated (the temperature in the passenger compartment is at set point)	11	
Current consumption [A] (600 V DC)	maximum (compressor speed at 50Hz)	22	
	regulated (the temperature in the passenger compartment is at set point $25^{\circ}\text{C}$ - ambient temperature $35^{\circ}\text{C}$ , reduced compressor speed)	9	
Weight [kg]		272	
Dimensions (length x wide x height) [mm]		2802x2091x406	
Operation voltage range [V DC]		450-750	
Refrigerant		R134A	
Filling capacity w/o front box[kg]		5	
Filling capacity with front box [kg]		5.5	

<sup>1)</sup>  $T_{\text{ambient}} = 35^{\circ}\text{C}$ ,  $T_{\text{cabin}} = 40^{\circ}\text{C}$

<sup>2)</sup>  $T_{\text{ambient}} = 5^{\circ}\text{C}$ ,  $T_{\text{cabin}} = 20^{\circ}\text{C}$

<sup>3)</sup> Version installed two times in articulated vehicle

3 Description of assemblies and components

3.1 REVO-E HP versions on the Volvo 79xx Electric



**REVO-E HP**  
(11120816\_) 1st generation - on solobuses

**REVO-E HP+**  
(11123865\_) 2nd generation - on solobuses und articulated variants

For connection to front box  
air conditioning only

REVO-E HP/HP+ (Zone 1)  
11120816\_ / 11123865\_

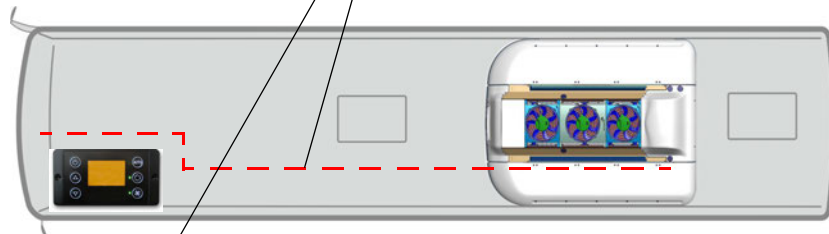

ADA on solobus

REVO-E HP+ (Zone 1)  
11123865\_

REVO-E HP+ (Zone 2)  
11123865\_

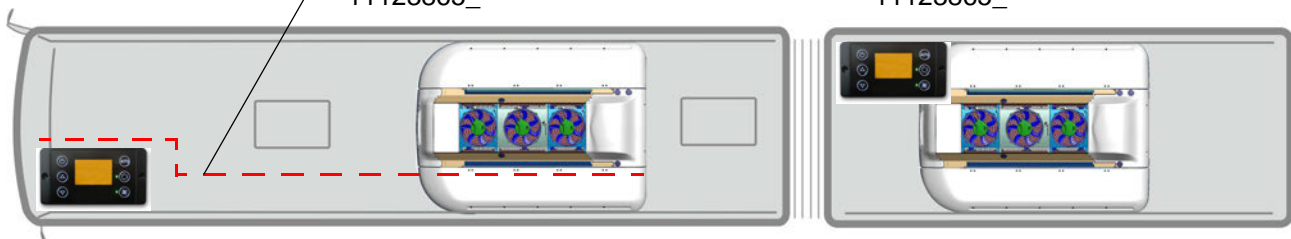

ADA on articulated system

Abb. 1 REVO-E HP Installation variants

3.2 Total overview of the design and components of the REVO-E heat pump

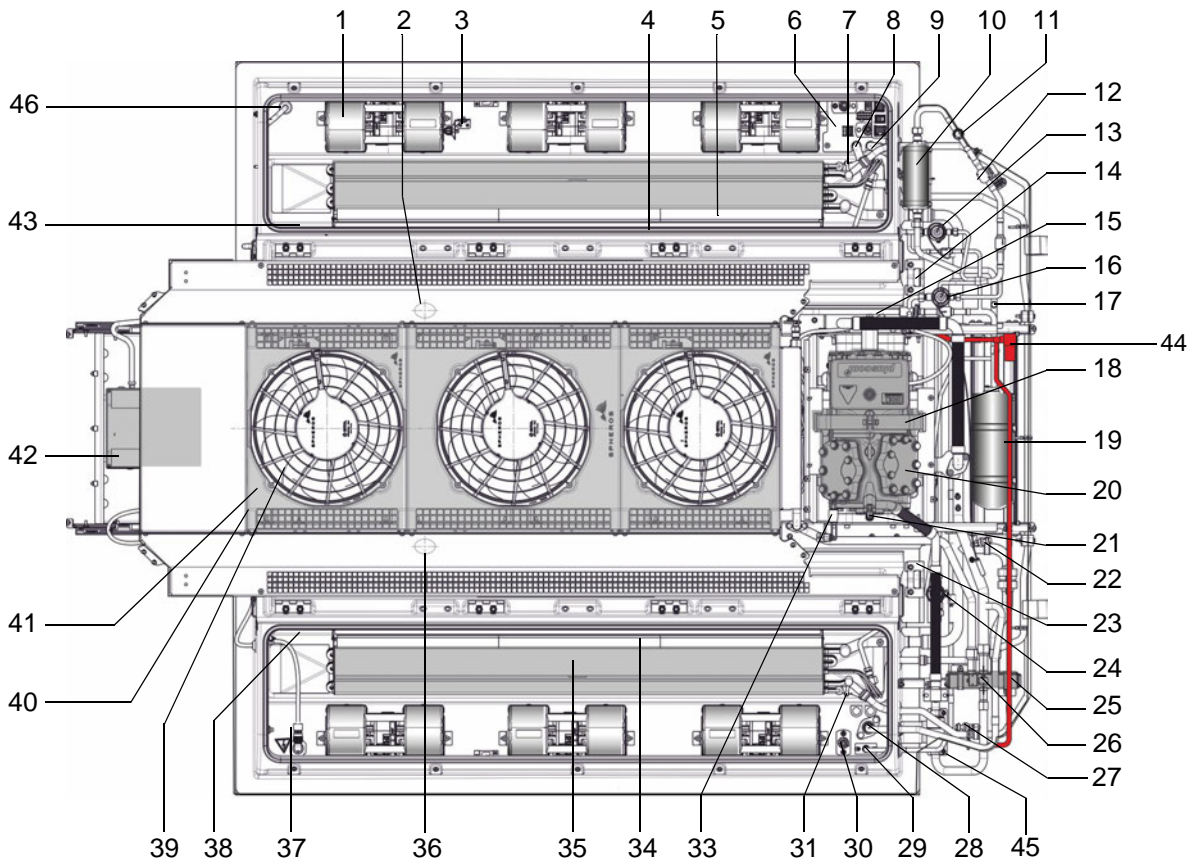

1) Figure shows 11123865\_  
 2) Red marked components in 11123865\_ only

←  
 Direction of travel

Fig. 2 REVO-E Heat pump total overview

- |  |  |  |
|--|--|--|
| 1 Double radial blower                               | heat pump  | 31 Bleeding port, heating element NW6              |
| 2 Right-hand forward safety lift point of the unit   | 17 Safety valve, 30bar                               | 32 Low pressure safety switch *                    |
| 3 Blow-out temperature sensor                        | 18 Bracket, refrigerant compressor                   | 33 High pressure safety switch                     |
| 4 Temperature sensor, passenger compartment (hidden) | 19 Refrigerant collector                             | 34 Air filter                                      |
| 5 Air filter   | 20 Refrigerant compressor                            | 35 Inner heat exchanger                            |
| 6 Electrical interface 24V                           | 21 Refrigerant charging valve, discharge side        | 36 Left-hand forward safety lift point of the unit |
| 7 Bleeding port, heating element NW6                 | 22 Suction pressure sensor (hidden)                  | 37 Electrical interface 600V DC                    |
| 8 Water feed flow NW20                               | 23 Left-hand rear safety lift point of the unit      | 38 Flap actuator (hidden)                          |
| 9 Water return NW20                                  | 24 Expansion valve cooling circuit                   | 39 Axial fan                                       |
| 10 Filter Dryer                                      | 25 4-way reversing valve                             | 40 Outer heat exchanger                            |
| 11 Sight glass                                       | 26 Coil 4-way reversing valve                        | 41 Fan module                                      |
| 12 Solenoid valve                                    | 27 High pressure sensor                              | 42 Frequency inverter                              |
| 13 Expansion valve cooling circuit                   | 28 Refrigerant connection, suction side, defroster   | 43 Flap actuator (hidden)                          |
| 14 Right-hand rear safety lift point of the unit     | 29 Refrigerant connection, discharge side, defroster | 44 Solenoid valve hot gas deicing                  |
| 15 Refrigerant charging valve, suction side          | 30 Protective Earth (PE), high voltage components    | 45 Muffler   |
| 16 Expansion valve heating circuit                   |  | 46 diagnostics port frequency inverter             |

\* not in 11123865\_

3.3 Overview of high-voltage cable harnesses / components (400V AC / 600V DC)

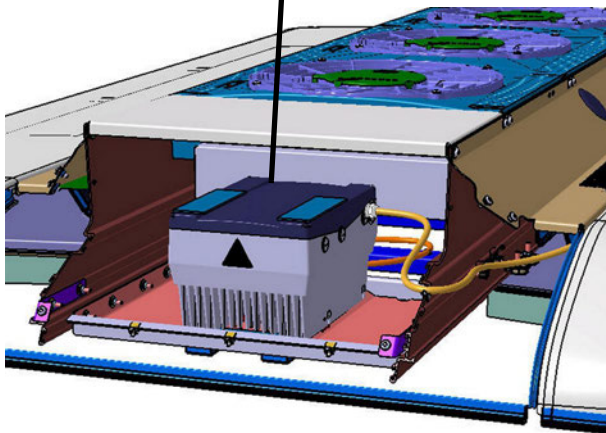
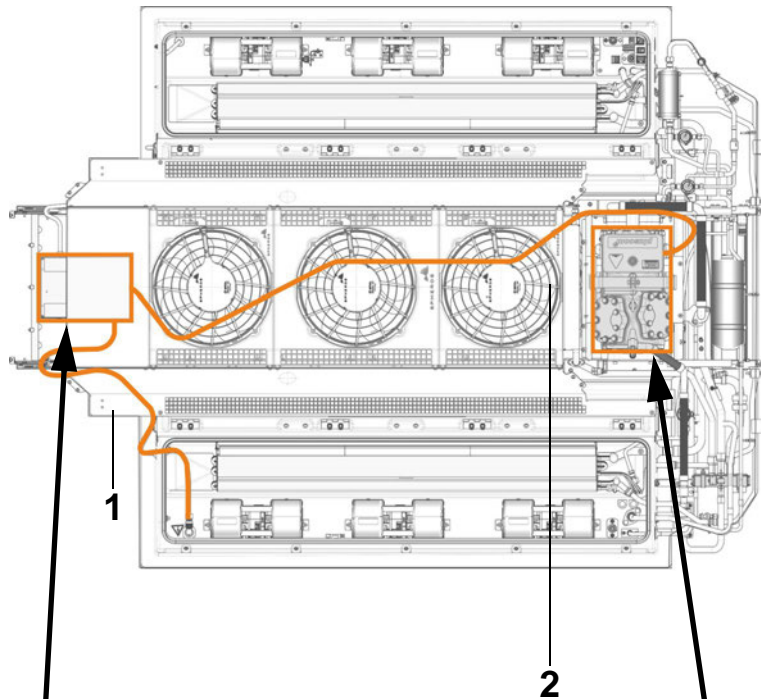

Frequency converter  
600V DC -> 3x400V AC

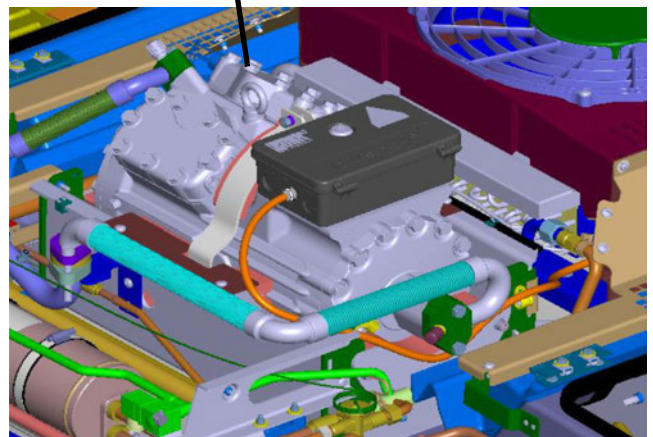

Compressor with 3x 400V AC e-motor

- 1 - High-voltage power supply of the frequency converter 600V DC
- 2 - High-voltage power supply of the compressor 3x 400V AC

Fig. 3 Overview of high-voltage cable harnesses / components (400V AC / 600V DC)

3.4 Cable harnesses overview (high-voltage / low-voltage) in the REVO-E HP

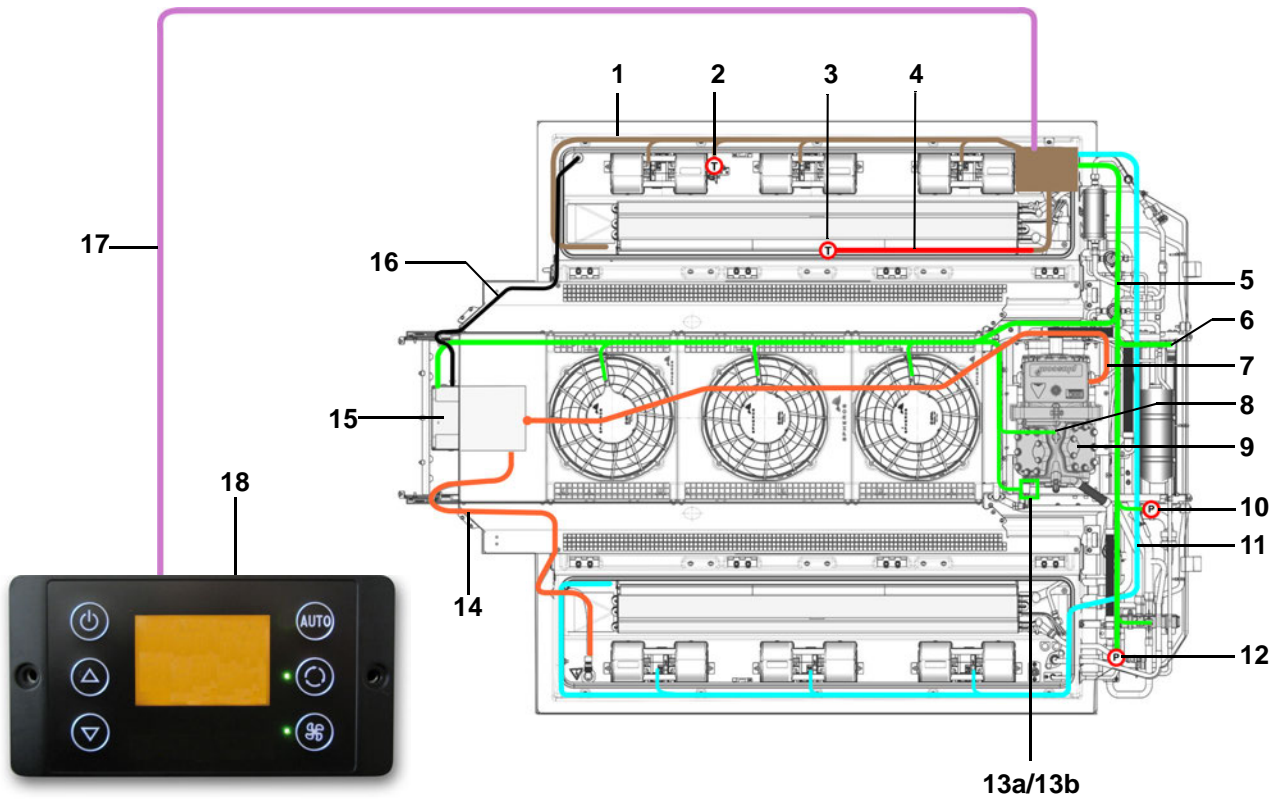

Item	Description	Remarks
1	wiring harness incl. connection board	24V interface ADA
2	temperature sensor	blow out temperature
3	temperature sensor	passenger compartment temperature
4	wiring harness	temperature sensor passenger compartment
5	wiring harness	axial fan, 4-way reversing valve
6	solenoid valve hot gas deicing	in 11123865_ only
7	wiring harness kit, 400V AC	frequency converter
8	PE connection compressor	
9	compressor	
10	suction pressure sensor	
11	wiring harness	double radial fan
12	high pressure sensor	
13a	high pressure safety switch	
13b	low pressure safety switch	not in 11123865_
14	wiring harness, 600V DC	HV interface, vehicle - frequency converter
15	frequency converter	600V DC -> 3x400V AC
16	diagnostic cable frequency converter	
17	wiring harness	control unit SC620 to ADA
18	SC620 control device	installed in Volvo E bus

Fig. 4 Cable harnesses overview (high-voltage / low-voltage) in the REVO-E HP



### 3.5 Design / task and function of the assemblies

The REVO-E heat pump features an outer and an inner heat exchanger. They consist of aluminum tubes and aluminum fins which are jointly connected and form a large heat exchanger surface.

**Outer heat exchanger**

In the air-conditioning mode it works as condenser. If the unit is in the heat pump mode, it is working as evaporator.

**Inner heat exchanger**

In the air-conditioning mode they work as evaporator. If the unit is in the heat pump mode, they are working as condenser.

**Condenser function**

It cools the hot refrigerant gas in such a way that it liquefies, subcools and transfers the condensation heat to the external air flowing through it via the fins.

**Evaporator function**

The evaporator absorbs the heat from its environment and delivers it to the refrigerant. In this process the evaporation temperature must be lower than the ambient temperature.

By the simultaneous suction action of the refrigerant compressor and the constriction of the expansion member, the desired evaporation temperature can be achieved in a targeted manner.

The heat flowing because of the temperature difference between the evaporator and the environment causes the refrigerant liquid fed in by the expansion element to evaporate (evaporation zone) and to overheat (overheating zone) in the evaporator.

**Compressor (HGX34P/315-2 A)**

This semi-hermetic, 4 cyl. reciprocating compressor is driven by a 2 pole, asynchronous motor integrated into the housing. It is flushed / cooled by R134a, a gaseous refrigerant, and an integrated PTC element monitors the temperature level. Signals are evaluated by the frequency converter. The frequency converter also provides power and controls the speed.

The duty of the compressor is to condense vaporous refrigerant from low pressure to a higher pressure. To do so, it must ensure the necessary discharge (refrigerant flow) required for cooling.

The compressor is integrated into the air-conditioning system. The compressor with patented vibration decoupling design is created using a special absorption foam. The compressor is embedded and fixed in this foam.

**Receiver**

The receiver is a compensating/ storage tank which

balances out changes in the refrigerant circuit.

**Dryer**

The interior of the dryer contains a granulate that removes small amounts of water from the refrigerant and chemically binds to it.

The dryer also filters contaminants from the refrigerant that might lead to malfunctions.

A further expansion valve for heat pump operation is installed in the heat pump.

**Thermostatic expansion valve**

The thermostatic expansion valve with external pressure equalization regulates the refrigerant flow to the compressor, depending on the refrigerant needs or the condenser temperature. The thermostatic expansion valve is the control element between the high and low pressure sections of the refrigerant circuit.

**Pressure switch**

The high and low pressure switches are installed on the compressor and are a key component of the safety chain of the air-conditioning system.

High pressure switch

- Monitors the pressure level in the high-pressure area of the refrigerant circuit
- Deactivates the air-conditioning system if pressure is too high (e.g. too much refrigerant)

Low pressure switch

- Monitors the pressure level in the low-pressure area of the refrigerant circuit
- Deactivates the air-conditioning system if pressure is too low (e.g. too little refrigerant)
- The low pressure switch is not installed in the 11123865\_ and is replaced by an SW algorithm.

Switch point

Switch point	High pressure switch	Low pressure switch <sup>1</sup>
On	19 ± 1.5 bar (relative)	1.8 ± 0.3 bar (relative)
Off	24 ± 1.0 bar (relative)	0.3 ± 0.3 bar (relative)

<sup>1</sup>) not in 11123865\_

**Axial fans**

The three axial fans are driven by EC motors.

If Cooling Mode is activated, the fans are continuously controlled depending on the load (refrigerant pressure) via the PWM, and provide the outer heat exchanger with sufficient fresh air.

**Double radial blowers**

The six double radial blowers are driven by EC motors. The blowers move recirculated / fresh air through the heat inner exchanger and blow it at the right temperature (depending on the mode) into the air ducts of the vehicle. Speed controls are continuous (PWM); e.g. speed is reduced when the desired passenger compartment temperature has been reached. This reduces energy needs and helps to stabilize the passenger cabin temperature.

**Frequency converter**

This component is supplied via the 600V DC electrical system of the vehicle and provides 400V AC for the three-phase AC motor of the compressor. Depending on system requirements, the compressor speed is set between 10Hz-50Hz.

The frequency converter is placed onto an adapter plate (Fig. 803), which makes it easy to remove / install.

**4-Way reversing valve**

Depending on the position, the 4-way reversing valve activates the air conditioning mode or the heat pump mode. In zero position, the air conditioning mode is active.

**Solenoid valve hot gas deicing REVO-E HP +**

The hot gas deicing solenoid valve is installed on the 11123865\_ ONLY. It is activated to defrost the outer heat exchanger with hot gas from the refrigerant circuit.

**Sensors***Suction pressure*

The suction pressure sensor determines the pressure level in the permanent low-pressure area. The system attempts to manage the suction pressure between 3.0 bar and 3.7 bar (absolute).

Central parameters for:

- climate/ heat pump control
- recognizing icing
- recognizing low pressure

*High pressure*

The high pressure sensor determines the pressure level in the permanent high-pressure area.

In heat pump mode, the target pressure is approx. 12 bar depending on the ambient temperature.

*Passenger compartment temperature*

This sensor measures the air temperature of the passenger cabin around the intake area of the recirculating air (Fig. 908).

*Air duct temperature (blow-out temperature)*

This sensor measures the air intake temperature of the air-conditioning system at the first double radial blower, front right (Fig. 908).

*Monitoring the temperature of the e-motor of the compressor*

A PTC element monitors the temperature of the compressor e-motor. The frequency converter evaluates the signal without directly influencing the air-conditioning control.

$R_{25} \leq 300 \Omega$

If the e-motor overheats, the frequency converter stops the compressor immediately (safety function).

**Air valves**

Regulate the intake of fresh air or use of recirculated air from the passenger cabin. The BEA body sends the positional signals "open / closed" via CAN to the SC620 in all operating modes (except for Gas Charging mode). If both signals are active, the valves will move to the Recirculating position. Intermediate positions (air mixing) are not provided in this vehicle.

**SC620**

This control unit is used as the control device in the Volvo 7900 Electro system (display / keyboard **inactive**).

HVAC demands are only managed by the BEA body, the SC620 works as a "slave system" and controls the functions of the ADA.

Two LEDs become active when the system is turned on (permanent & blinking).

## 4 Function and functional schematics of the REVO-E Heat pump

### 4.1 General function

The fully electric rooftop air-conditioning system (in the following referred to as ADA) REVO-E for hybrid, electric and trolley buses is a proven system, especially with its intelligent energy management, meaning cooling is provided as needed depending on existing power, and with the special way its compressor has been installed. The electric compressor is located on the roof in an exceptionally compact manner, and not on the rear of the vehicle as in previous versions. This has, in the purest sense of the word, obvious advantages and makes the system closed by integrating all of the components carrying refrigerant, an efficient, tight and almost maintenance free design (solo design without front box connection).

#### The REVO-E as heat pump

The REVO-E air-conditioning system is the basis for the REVO-E heat pump.

The refrigeration cycle of the REVO-E air-conditioning system has been modified in such a way that it can also represent the functionality of a heat pump in addition to the air-conditioning operation. The basic principle is based on the reversal of the refrigeration cycle.

Regulation and control in the air-conditioning mode correspond to the REVO-E air-conditioning system. Details can be found in the Workshop Manual REVO-E.

Explanations in the following chapters refer largely to the new functions of the heat pump.

The intelligent controller logic of the SC620 controls further the entire system. It communicates with the vehicle via CAN bus.

The climate control works identical as in the REVO-E

air-conditioning system (see Workshop Manual REVO-E).

The two variants of the REVO-E HP are listed in the [Table 201](#).

Both systems differ only slightly. With the additional function "hot gas de-icing", the REVO-E HP + is able to heat the passenger compartment in heat pump mode at significantly lower temperatures ( $\geq -5$  °C). This is realized with adapted software and additional components in the refrigeration cycle.

#### Functionality of the REVO-E Heat pump in the vehicle line of the Volvo 7900 Electric

The HVAC control system of the vehicle is responsible for regulating the Heating, Ventilation and Cooling modes in the Volvo E Bus. The REVO-E system is operated only as a "slave" system and only follows the vehicles requirements.

If the ADA is activated by switching on the vehicles electrical network. all of the system's sensor values are automatically verified for plausibility and the system will be set to "Standby Mode". Various sensor values are used as the basis for calculating the bus-side requirements, including those from the passenger cabin sensors of the ADA.

These requirements are sent via CAN bus over the Dbus to the SC620 as needed.

The SC620 implements these requirements (mode / blower speed, etc.).

The REVO-E will turn off if there are any limitations in the temperature / high-voltage supply, etc.



4.2 Functional schematic of the REVO-E heat pump

Tasks of the SC620

- Implementing climatic and heat pump requirements
- Turning off high-voltage components in case of error (HVIL)
- Component protection of the climate unit if overloaded

- Power supply clamp 30 (main switch of battery)
- Ignition on (clamp 15)
- CAN communication between vehicle and SC620 activated - approval for system start shared
- High voltage to the frequency converter, that means high voltage system active
- Approval (D\_AuxiliaryPowerEnable) and supply

Required to start the system:

**NOTE:**

Details about the positions can be found in the overview Fig. 2 in Chapter 3 of the workshop manual.

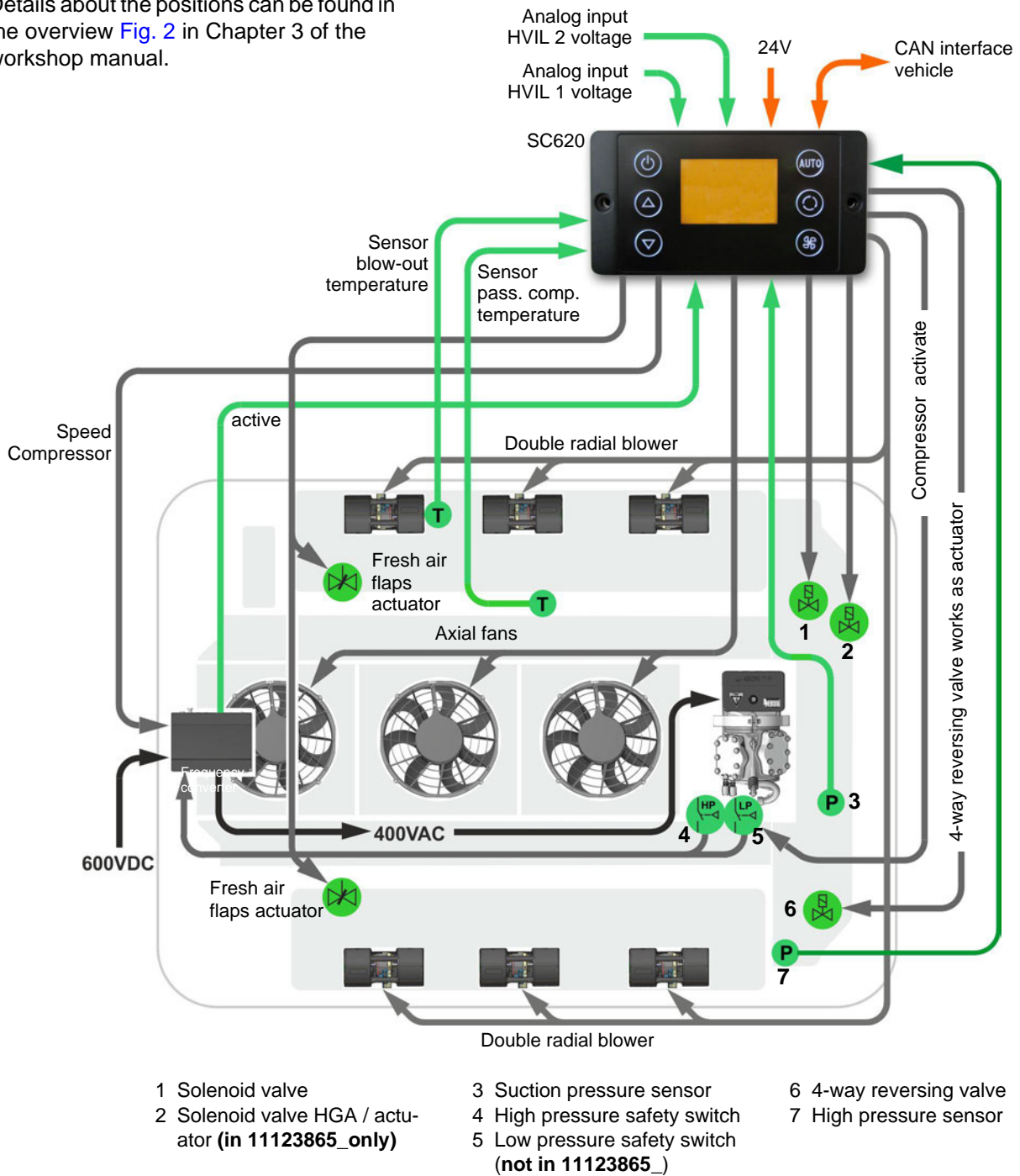

Fig. 401 Functional schematic of the REVO-E

4.3 Functional schematic of the REVO-E heat pump Volvo 7900 Electric

On single buses, the ADA and SC620 are connected to one another using a Valeo cable harness. The HVAC control system of the BEA body system is responsible for regulating the Heating, Ventilation, Cooling and Heat pump modes in the Volvo e-bus. The REVO-E system therefore behaves only as a “slave”

system and implements the particular requirements. In Heating / Ventilation or Reheat Mode, the vehicle controller gives the speed of the double radial blowers. In Cooling, Waste Energy or Gas Charging Mode, the double radial blowers are controlled by the SC620.

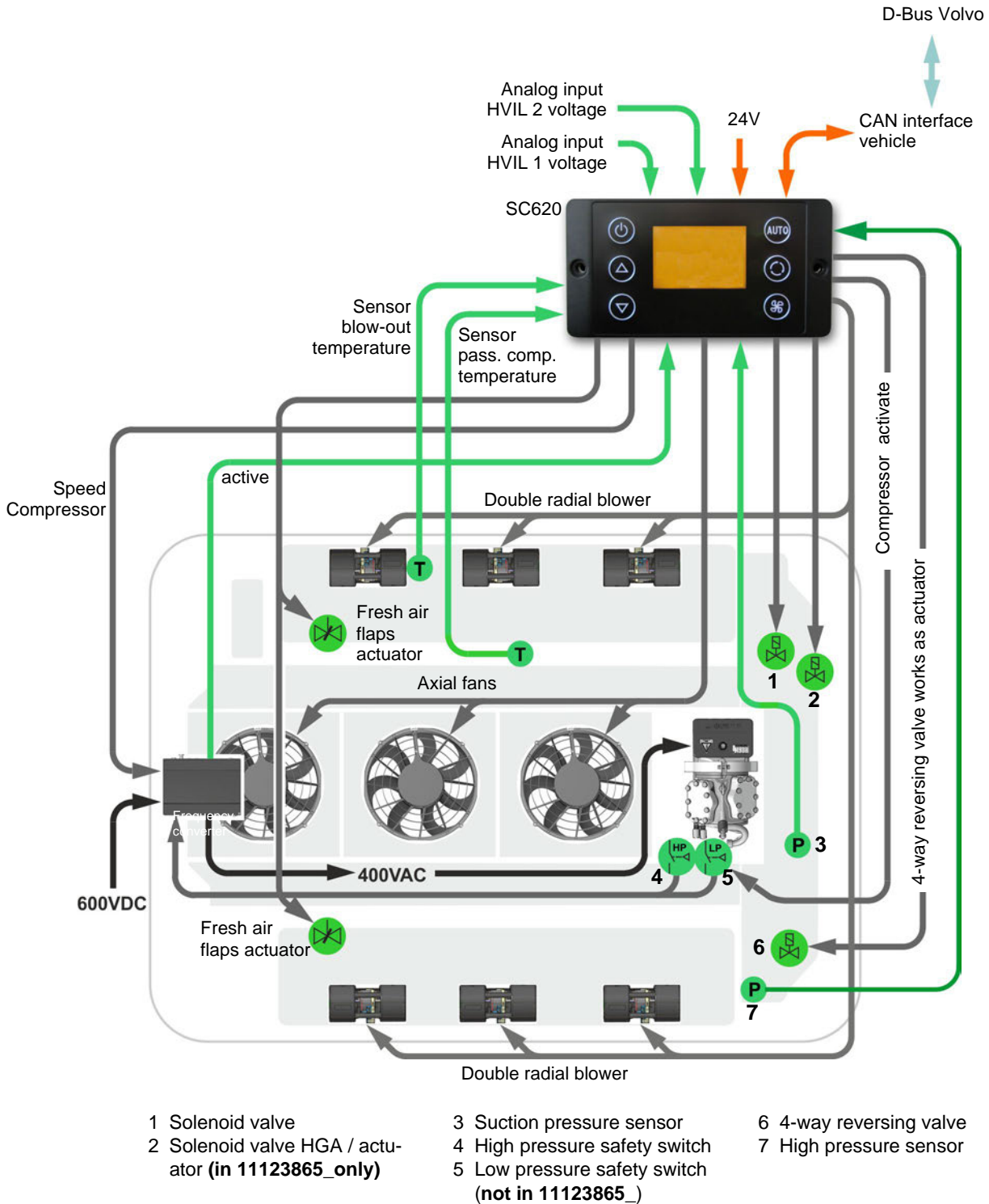

Fig. 402 Functional schematic of the REVO-E, internal

#### 4.4 Work modes of the REVO-E heat pump in the Volvo 7900 Electric

There are 9 different operating modes.

The well-known 6 operating modes of the REVO-E air-conditioning system (see WM REVO-E) are extended by three working modes.

In the following explanations, only the new working modes are considered.

Choosing or switching between modes occurs according to defined criteria of the BEA body climate control system.

1. Heating/ Ventilation Mode
2. Heating/ Ventilation Mode Ready for Cooling
3. Heating/ Ventilation Mode Ready for Heat Pump \*
4. Cooling Mode
5. Heat Pump Mode \*
6. De-Icing Mode \*\* (11123865\_only)
7. Reheat Mode
8. Waste Energy Mode
9. Gas Charging Mode

\*) new mode for heat pump

\*\*) in 11123865\_only

This is a list of priorities in case several modes are simultaneously required by the BEA body system. The SC620 must employ the mode with the highest priority.

Operating mode De-Icing (in 11123865\_ only)

This mode is activated by the SC620 depending on the state of icing. The BEA body control is only informed about the mode. In this mode, the heat pump function is disabled.

General operating mode conditions:

- mode required by BEA body (e.g. Cooling Mode to reduce the temperature in passenger compartment or Heat Pump Mode to increase the temperature in passenger compartment)
- general system conditions (e.g. external temperatures / status of 600V DC system)
- operating mode de-icing not activated

Depending on the mode, the SC620 or BEA body system will control the actuators.

4.4.1 Heating and Ventilation Mode (HV Mode)

Requirements:

- Clamp 30 active
- HV Mode required by BEA body

Both modes are required directly by the BEA body.

CAN messages from the BEA body to SC620 for defined speed of double radial blowers and position of air flaps (fresh air / recirculating air).

Water valves are controlled by the BEA body directly.

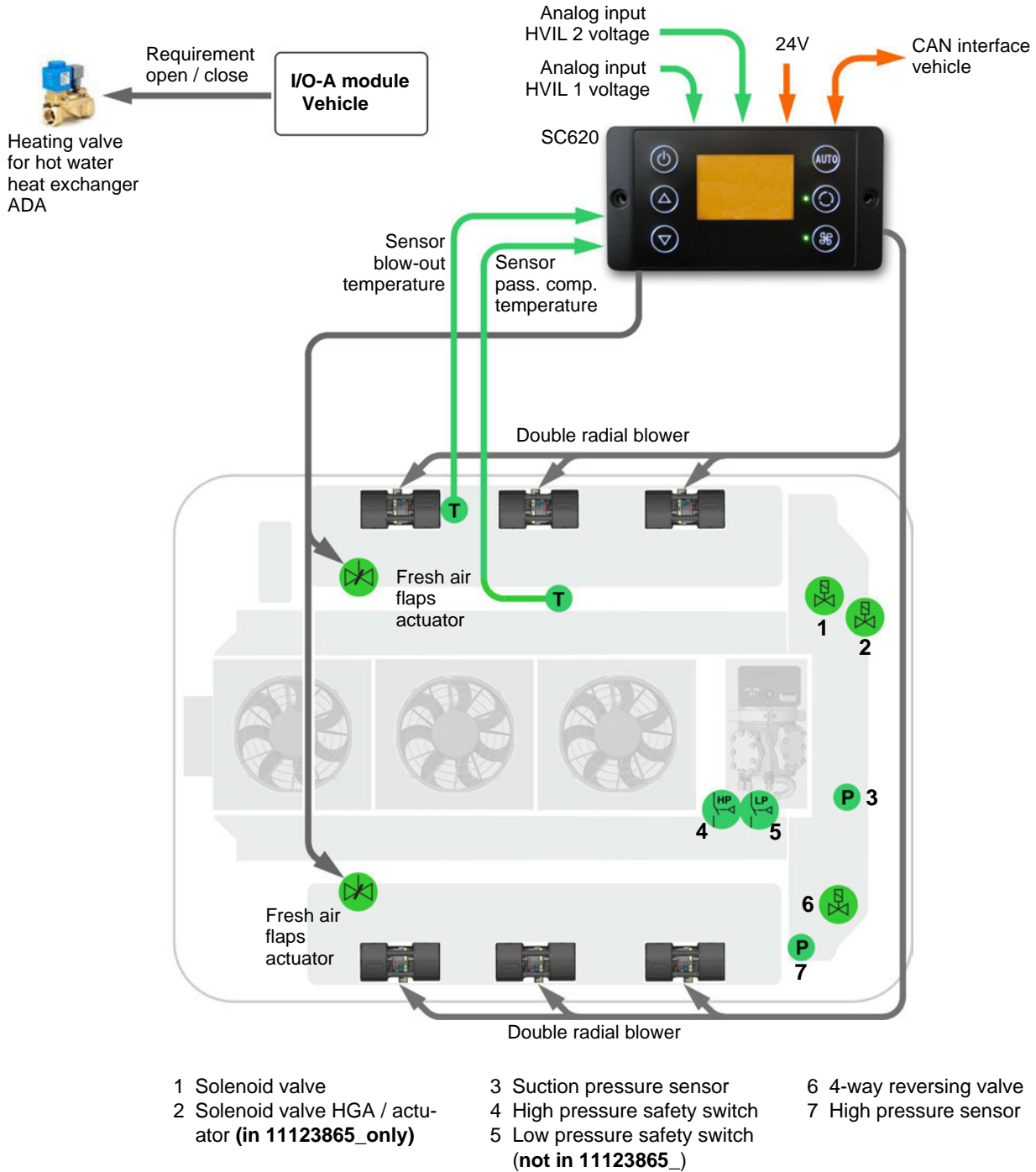

Fig. 403 Heating and Ventilation Mode (HV Mode)

4.4.2 Heating and Ventilation Mode Ready for cooling

Requirements:

- Clamp 30 / 15 active
- Vehicle hybrid system active
- HV Mode required by BEA body

Preconditions for Cooling Mode filled shortly before or after this, however cool request not sent by BEA body. System works primarily in Heating / Ventilation Mode.

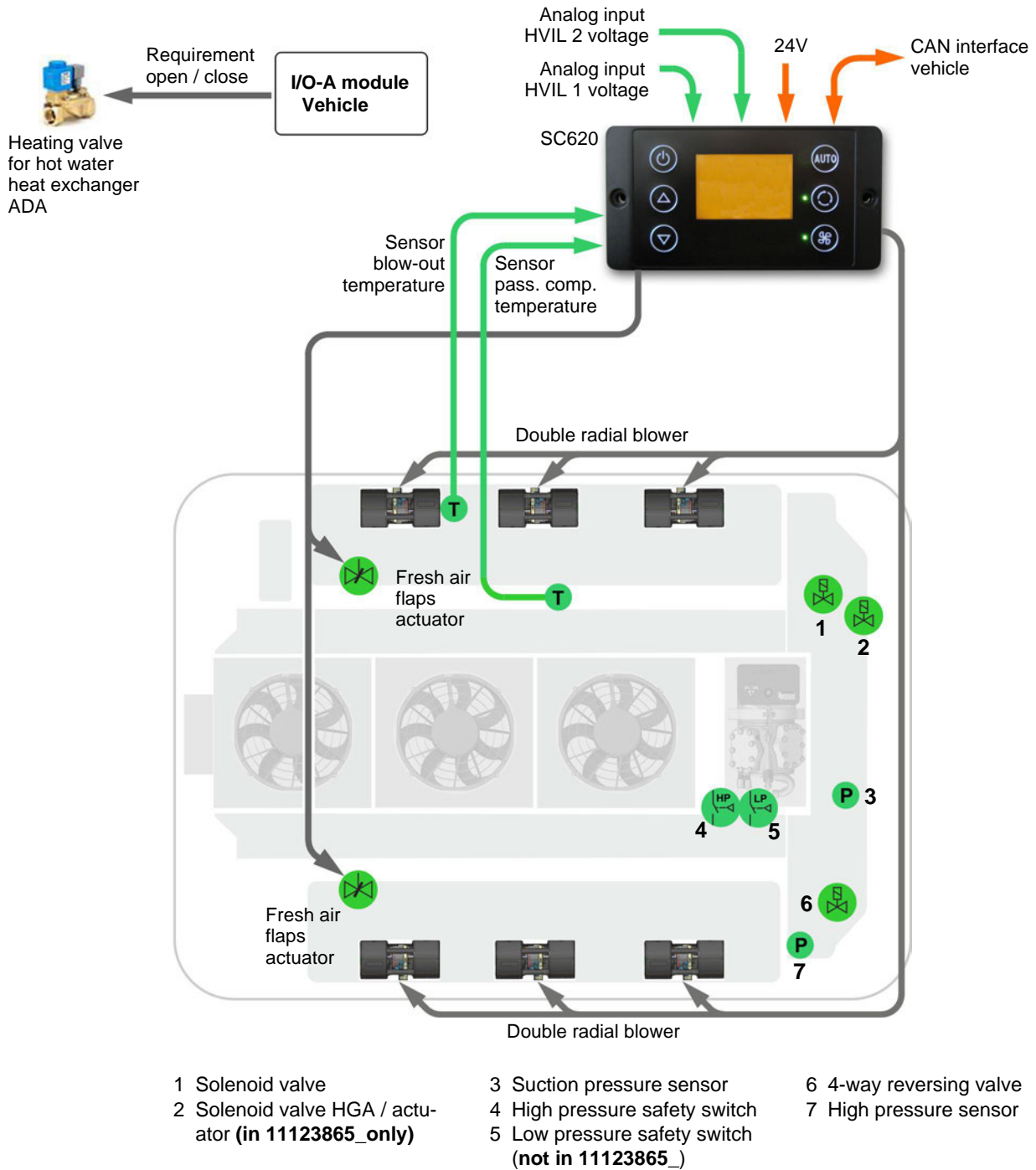

Fig. 404 Heating and Ventilation Mode Ready for Cooling

4.4.3 Heating and Ventilation Mode Ready for Heat Pump Mode

Requirements:

- Clamp 30 / 15 active
- Vehicle hybrid system active
- HV Mode required by BEA body

Preconditions for Heat Pump Mode filled shortly before or after this, however cool request not sent by BEA body. System works primarily in Heating / Ventilation Mode.

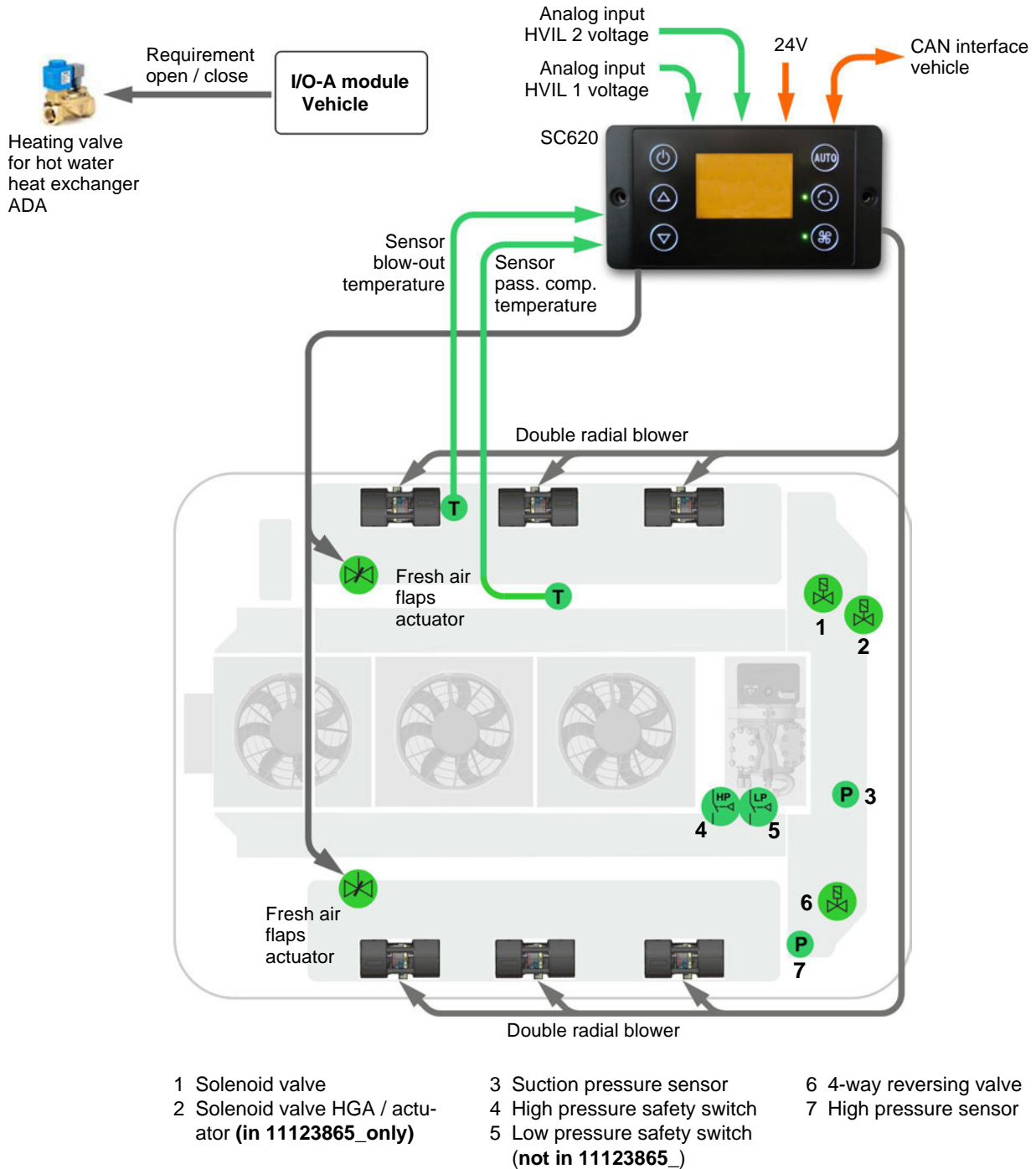

Fig. 405 Heating and Ventilation Mode Ready for Heat Pump



4.4.4 Cooling Mode

Requirements:

- Terminal 15 active
- Vehicle hybrid system active
- Mode "Ready for Cooling" active
- HVAC power consumption enabled by "D\_AuxiliaryPowerEnabled" signal
- Signal "D\_CabinCoolReq" sent by BEA-Body

- environmental temperature > 5°C

The Cooling Mode is requested by the BEA body system in order to cool down the air in the passenger cabin. The SC620 therefore assumes internal control of the components in the system in order to cool down the air in the passenger cabin to the Delta T value requested by the BEA Body.

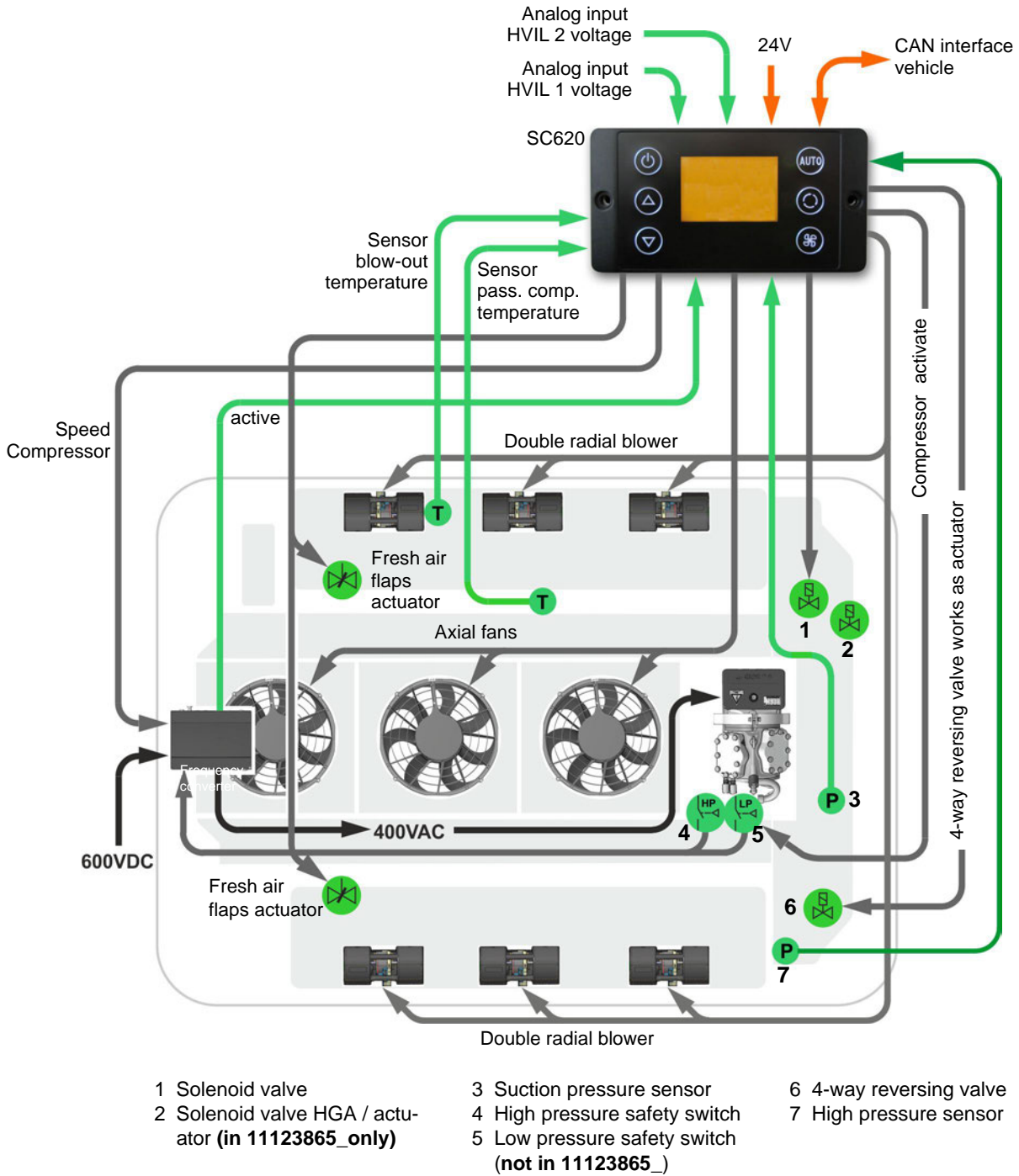

Fig. 406 Cooling Mode

Task of the SC620:

- Control the speed of the double radial blowers / axial fans
- Activation and speed setting of the compressor (via frequency converter)

In Cooling mode Mode, the BEA body is not able to influence the speed of the double radial blowers.

The value of the interior temperature to be reached is given by the difference of the external temperature and the  $\Delta T$  required by the BEA body.

*Example of  $\Delta T$  – 7 Kelvin*

$$T_{\text{passenger cabin}} = [T_{\text{external}} (35^{\circ}\text{C}) + \Delta T (7\text{K})]$$
$$T_{\text{passenger cabin}} = 28^{\circ}\text{C}$$

This value is sent via CAN by the BEA body and is used as an internal control signal.

The "D\_EIAcMaxPowerAllowed" CAN signal (from the vehicle's power system) specifies the maximum power consumption of the compressor.

If the cooling requested cannot be implemented (e.g. malfunction), the system automatically switches to Heating/ Ventilation Mode.



4.4.5 Heat Pump Mode

Requirements:

- Environmental temperature  $\geq -5^{\circ}\text{C}$  (11123865\_)
- Environmental temperature  $\geq 3^{\circ}\text{C}$  (11120816\_)
- no frequency converter or compressor errors
- no low-voltage error
- Terminal 15 active
- Vehicle hybrid system active

- HVAC power consumption enabled by "D\_AuxiliaryPowerEnabled" signal
- no HVIL error
- $\Delta T$  temperature passenger compartment  $> 0\text{K}$
- SC620 CAN message "heat pump available" to BEA body
- "D\_CabinHeatpumpReq" signal sent by BEA body

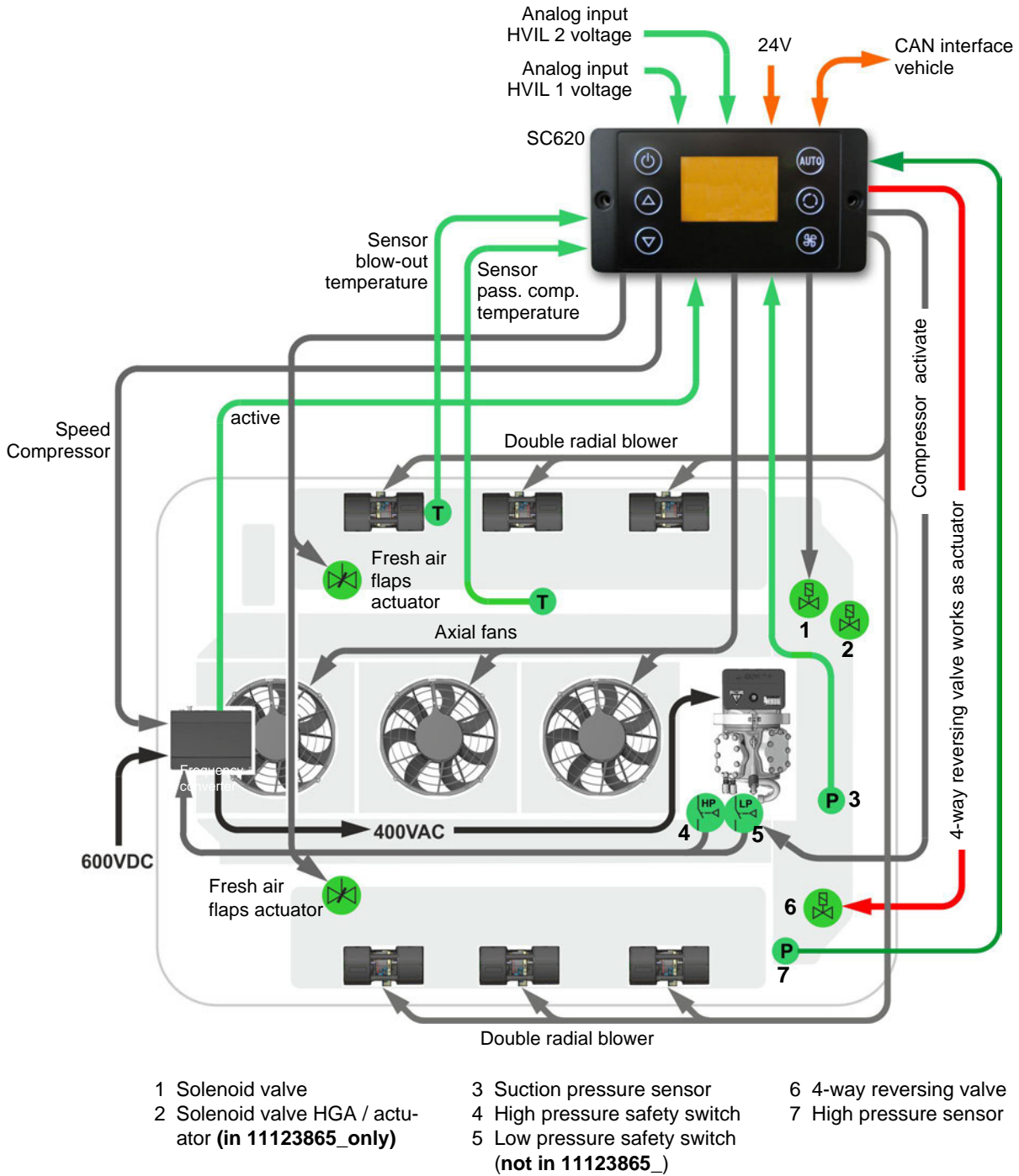

Fig. 407 Heat Pump Mode

The Heat Pump Mode is requested by the BEA body system in order to warm up the air in the passenger cabin. The SC620 therefore assumes internal control of the components in the system in order to warm up the air in the passenger cabin to the Delta T value requested by the BEA Body.

In the heat pump mode, the refrigerant circuit to the front box (driver's work station) is closed by a solenoid valve controlled of the BEA-Body SW. This prevents a sudden fogging of the front windscreen (flash fogging).

Task of the SC620:

- Control the speed of the double radial blowers / axial fans
- Activation and speed setting of the compressor (via frequency converter)

In Heat Pump Mode, the BEA body is not able to influence the speed of the double radial blowers.

The value of the interior temperature to be reached is given by the difference of the external temperature and the  $\Delta T$  required by the BEA body.

*Example of  $\Delta T$  – 7 Kelvin*

$$\begin{aligned}T_{\text{passenger cabin}} &= [T_{\text{external}} (10^{\circ}\text{C}) + \Delta T (7\text{K})] \\T_{\text{passenger cabin}} &= 17^{\circ}\text{C}\end{aligned}$$

This value is sent via CAN by the BEA body and is used as an internal control signal.

The "D\_EIAcMaxPowerAllowed" CAN signal (from the vehicle's power system) specifies the maximum power consumption of the compressor.

If the heat required cannot be implemented (e.g. malfunction), the system automatically switches to Heating/ Ventilation Mode.

**4.4.6 Operating Mode De-Icing)  
(Version HP+ only)**

Requirements:

- Start of Heat Pump Mode or 1h Heat Pump Mode operation
- Environmental temperature  $\geq -5^{\circ}\text{C}$  (REVO-E HP+)
- no frequency converter or compressor errors
- no low-voltage error
- Terminal 15 active
- Vehicle hybrid system active
- HVAC power consumption enabled by "D\_AuxiliaryPowerEnabled" signal
- no HVIL error
- $\Delta T$  temperature passenger compartment  $> 0\text{K}$
- SC620 CAN message "heat pump available" to BEA body
- "D\_CabinHeatpumpReq" signal sent by BEA body.

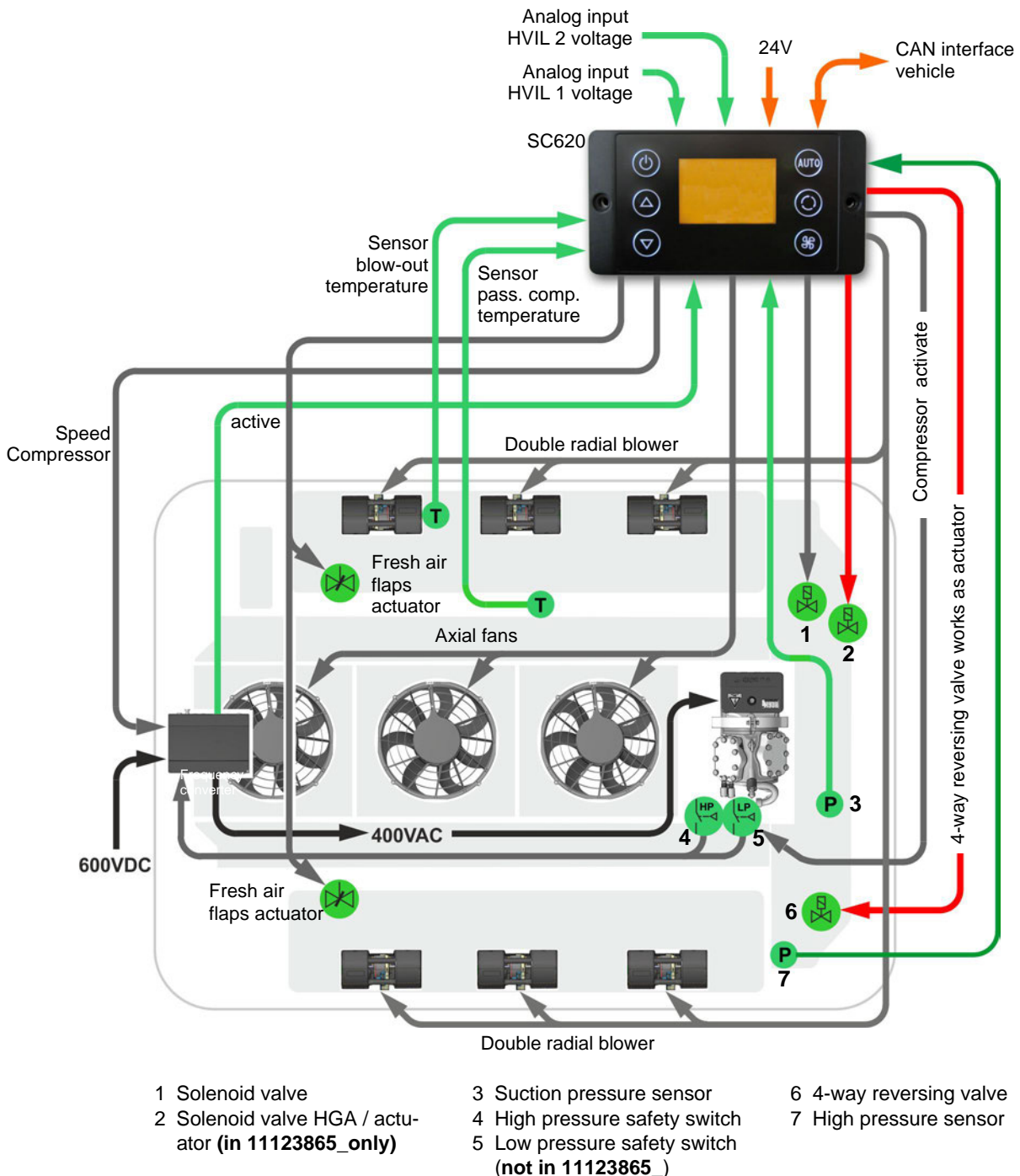

Fig. 408 Operating Mode De-Icing

This mode is only available with the REVO-E HP + (additional solenoid valve) and allows the use of the system up to an outside temperature of  $-5^{\circ}\text{C}$ .

For component safety, the SC620 starts the De-Icing Mode each time before starting the heat pump function. Furthermore, the de-icing is activated after one hour Heat Pump Mode and takes between 2 min and 15 min depending on the degree of icing of the outer heat exchanger. In order to use the necessary energy for the fastest possible de-icing, the double radial blowers are switched off during this time.

The BEA body control is informed via CAN from the SC620 about the mode and heats the passenger compartment via the floor heating circuit.

#### **4.4.7 Operating Mode Oil Recovering (Version HP+ only)**

Serves to protect the compressor.

After approx. 4 hours in heat pump mode, the ADA switches to the oil return mode. The refrigeration oil distributed in the ADA is thus returned to the compressor.

4.4.8 Reheat Mode

Requirements:

- Clamp 15 active (ignition)
- Vehicle hybrid system active
- The HVAC's power needs are enabled by the signal "D\_AuxiliaryPowerEnabled"
- "D\_CabinReheatReq" signal is requested by the BEA body
- Environmental temperature >5°C

Reheat Mode is requested by the BEA body (air drying in passenger compartment).

The SC620 activates the compressor and the axial fans for maximum cooling.

The BEA body system activates the valves of the roof-top heater simultaneously. Hot coolant is delivered to the heat exchangers of the ADA.

The counter-heating in reheat mode is carried out via the water heat exchangers installed in the system. The heat pump function can not do this.

The maximum condenser capacity can be limited by the "D\_EIACMaxPowerAllowed" signal.

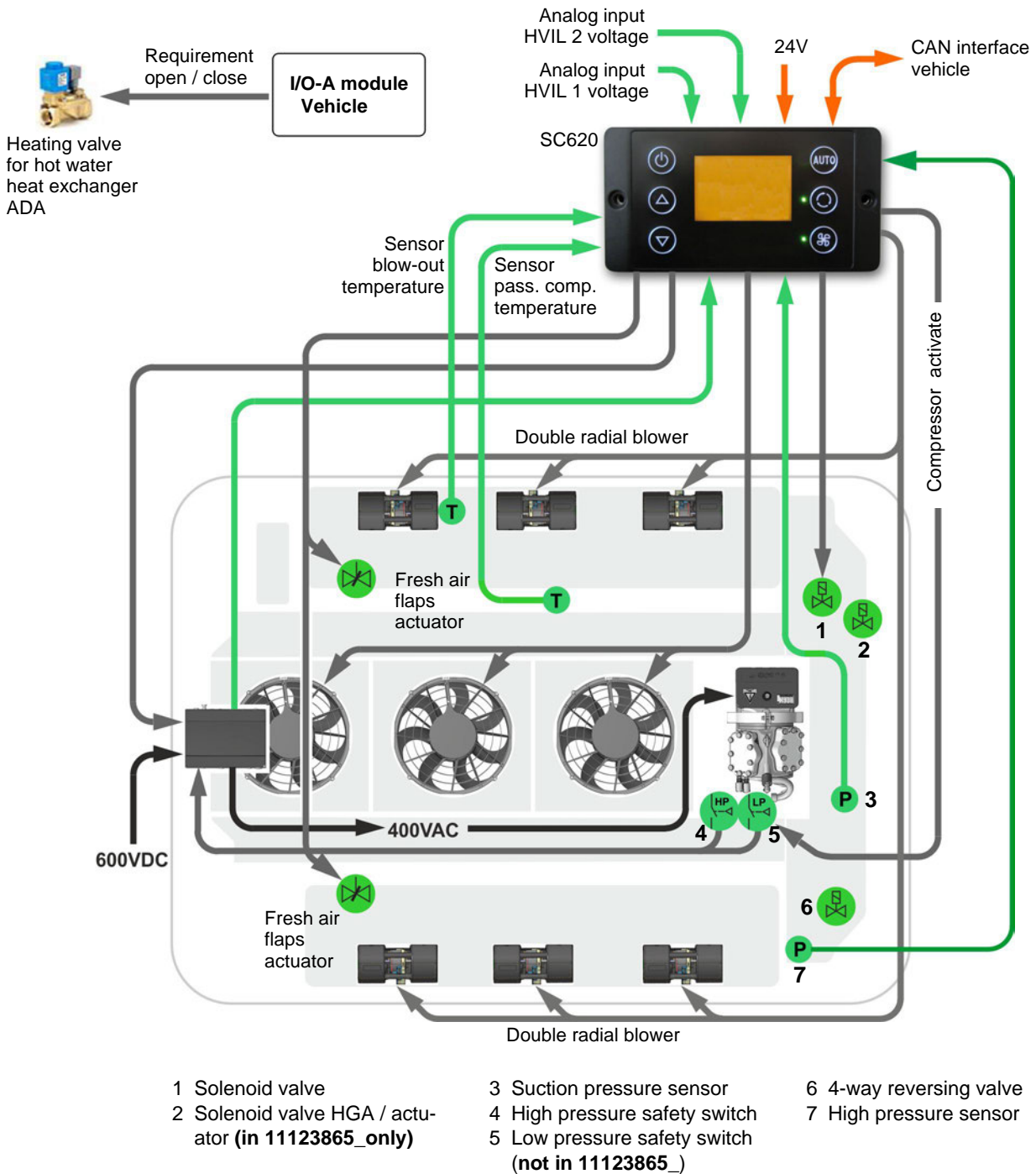

Fig. 409 Reheat Mode

#### 4.4.9 Waste Energy Mode

Requirements:

- Clamp 15 active (ignition)
- Vehicle hybrid system active
- The HVAC's power needs are enabled by the signal "D\_AuxiliaryPowerEnabled"
- "D\_CabAcWasteEnergyReq" signal is requested by the BEA body
- Environmental temperature  $>5^{\circ}\text{C}$

In Waste Energy Mode, the air-conditioning system attempts to dissipate additional energy from the drive battery.

This is achieved by running back the efficiency of the air-conditioning system, e.g. by reducing the speed of the axial fans.

The reduction in power must occur without any noticeable change to the conditions in the passenger cabin. This mode is only used to support the power management system.

The maximum condenser capacity can in turn be limited by the "D\_EIACMaxPowerAllowed" signal.

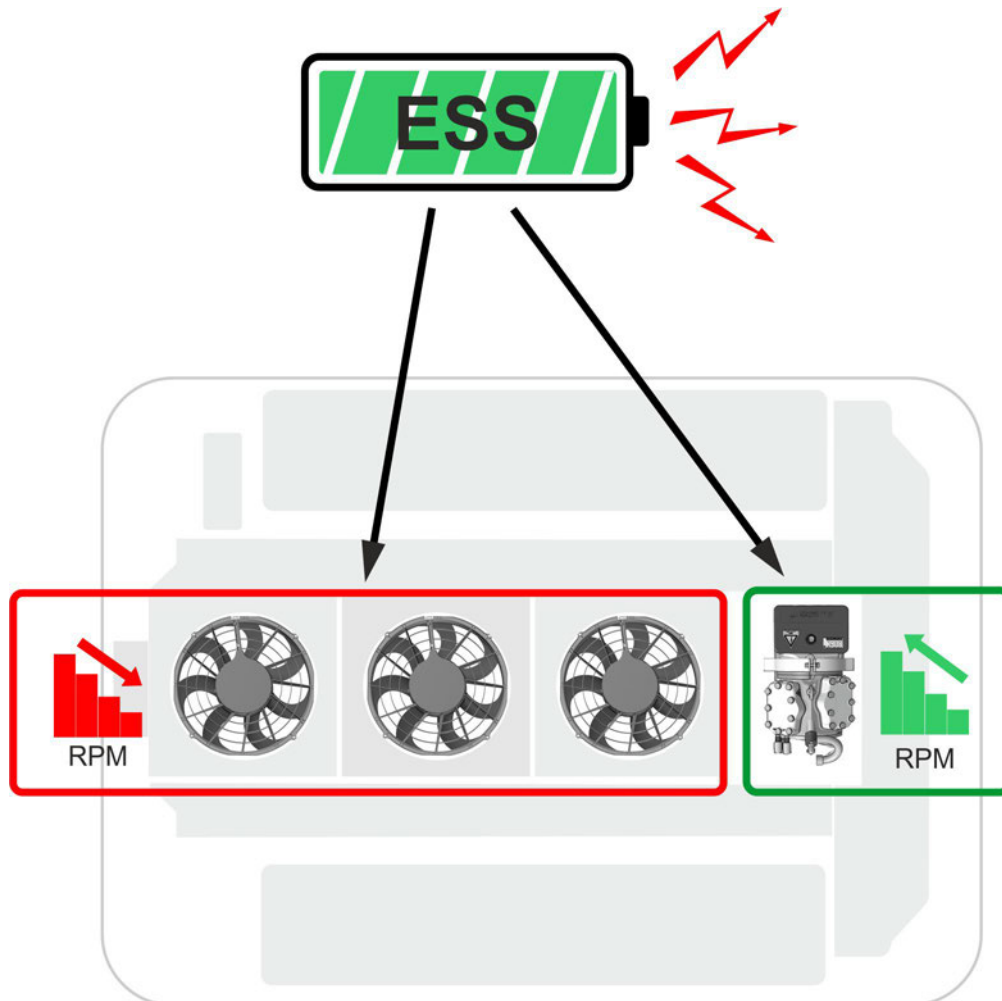

Fig. 410 Waste Energy Mode

4.4.10 Gas Charging Mode

Requirements:

- Clamp 15 active (ignition)
- Vehicle hybrid system active
- The HVAC's power needs are enabled by the signal "D\_AuxiliaryPowerEnabled"
- "D\_CabAcGasCgeReq" signal is requested by the BEA body
- Environmental temperature >5°C

The task of Gas Charging Mode is to activate the compressor to fill the system with the refrigerant R 134a.

Gas Charging Mode works independently with a small  $\Delta T$  that is sent by the BEA body to the SC620.

This activates the compressor, the double radial blowers / axial fans of the REVO-E at **minimal power**.

**Monitoring of the suction pressure is deactivated in Gas Charging Mode, since the system is normally not filled when this mode is started and the suction pressure sensor would therefore read a false value in the vacuum of the system. \***

The mode is not part of standard operation and is only to be used by trained servicing personnel.

The maximum condenser capacity can be limited by the "D\_EIACMaxPowerAllowed" signal.

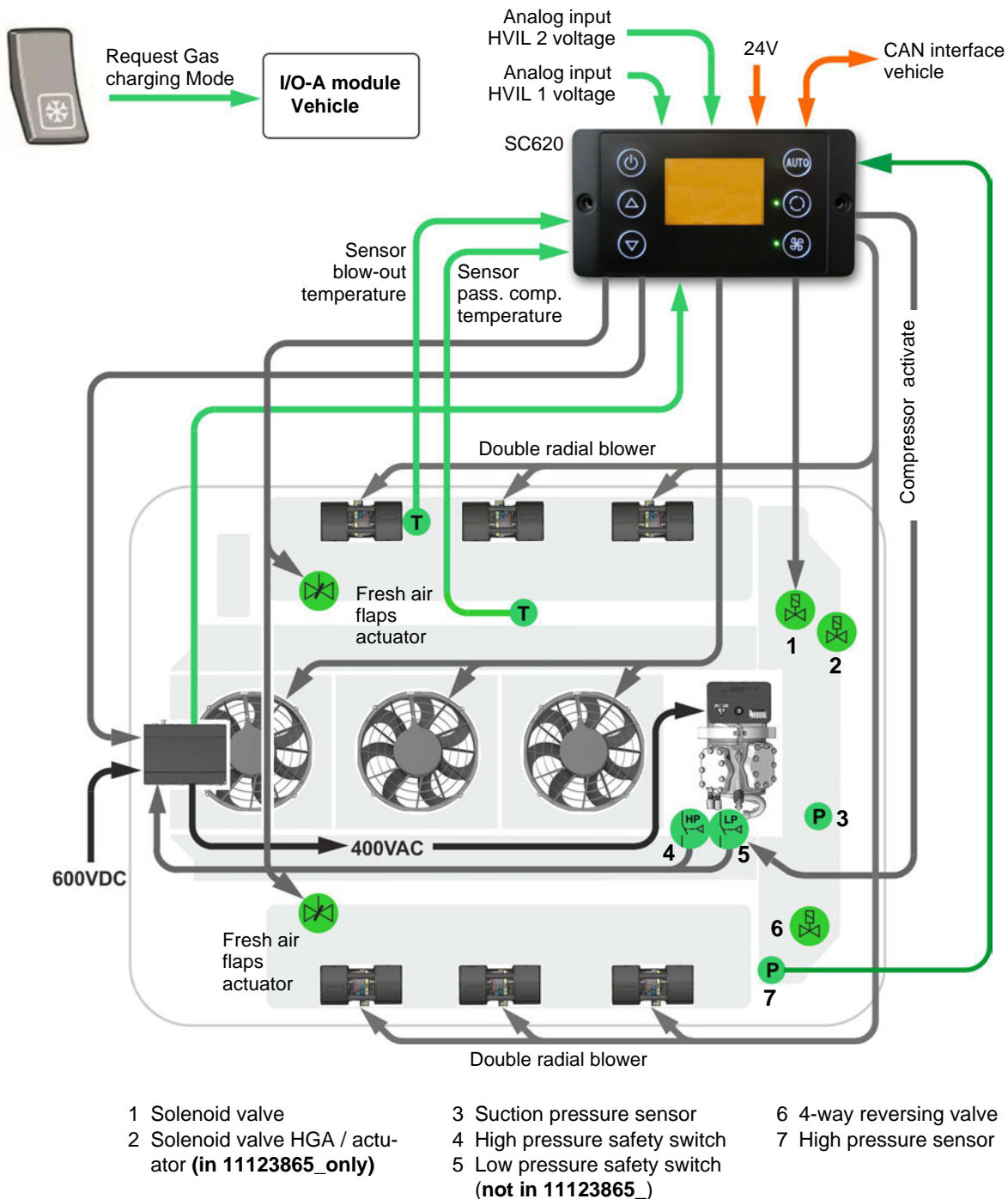

Fig. 411 Gas Charging Mode



4.5 Refrigerant circuit function schematic of the heat pump

The refrigerant circuit of the REVO-E heat pumps can be reversed via a 4-way reversing valve. This changes the function of the evaporator and the condenser, as they are known from the REVO-E air conditioning.

Die Verdampfer arbeiten im Wärmepumpen-Modus als Kondensator und der Kondensator arbeitet als Verdampfer. Additional components such as a modified pipe circuit, various check valves and a further expansion valve support the circulation reversal.

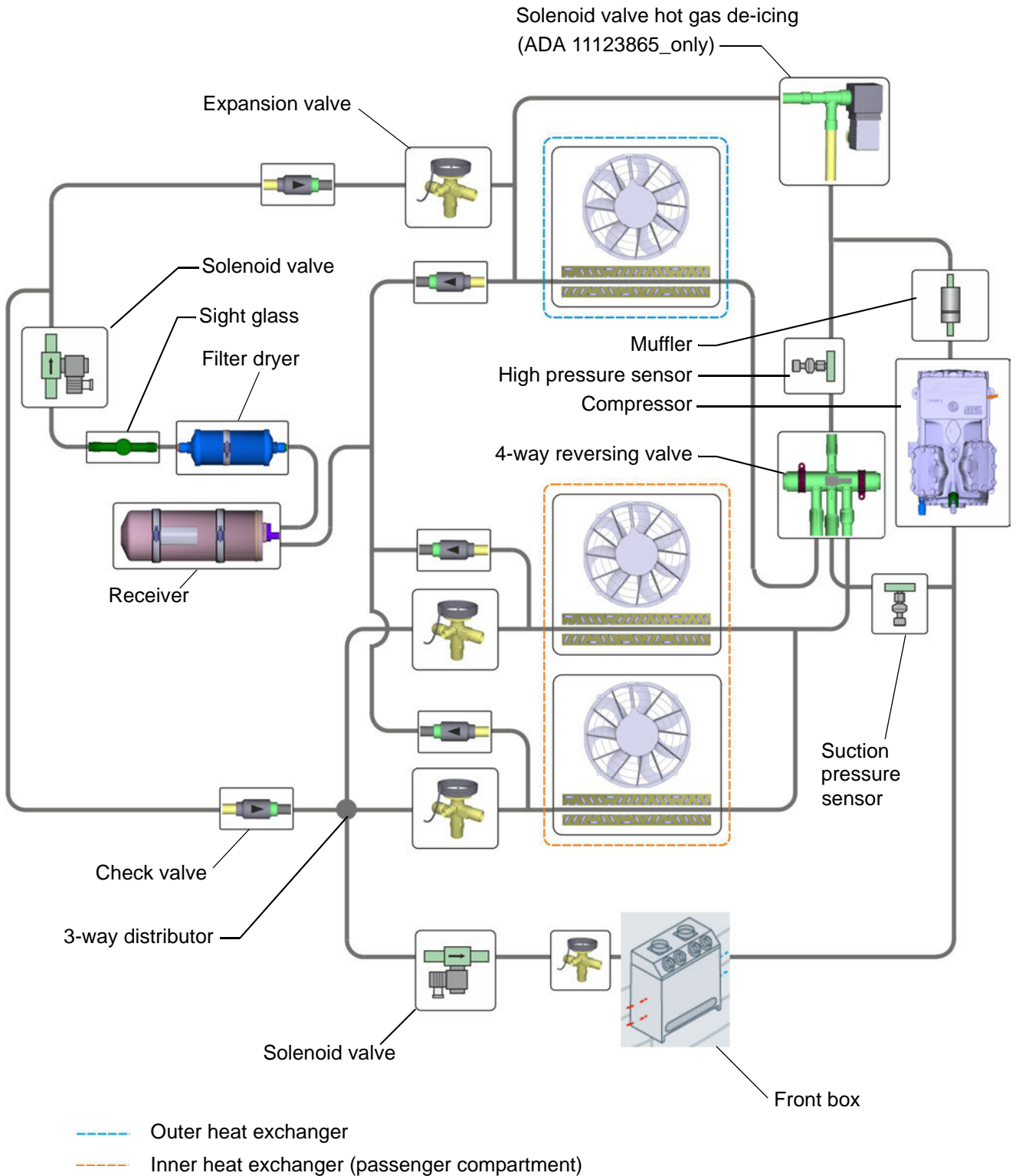

Fig. 412 Refrigerant circuit function schematic of the heat pump



4.5.1 Refrigerant circuit function schematic of the heat pump in the Cooling Mode

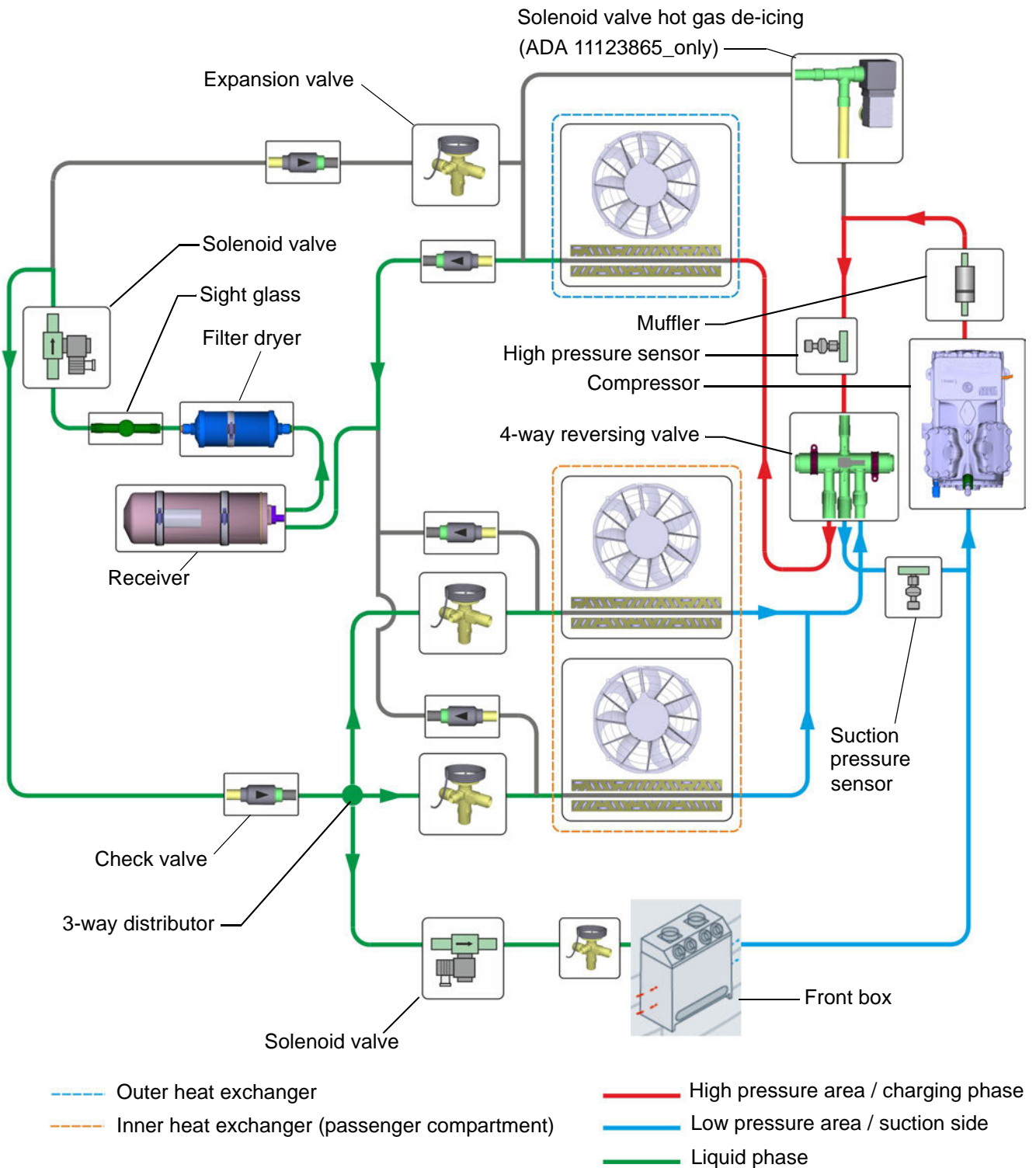

Fig. 413 Refrigerant circuit function schematic of the heat pump in the Cooling Mode

4.5.2 Refrigerant circuit function schematic of the heat pump in the Heat Pump Mode

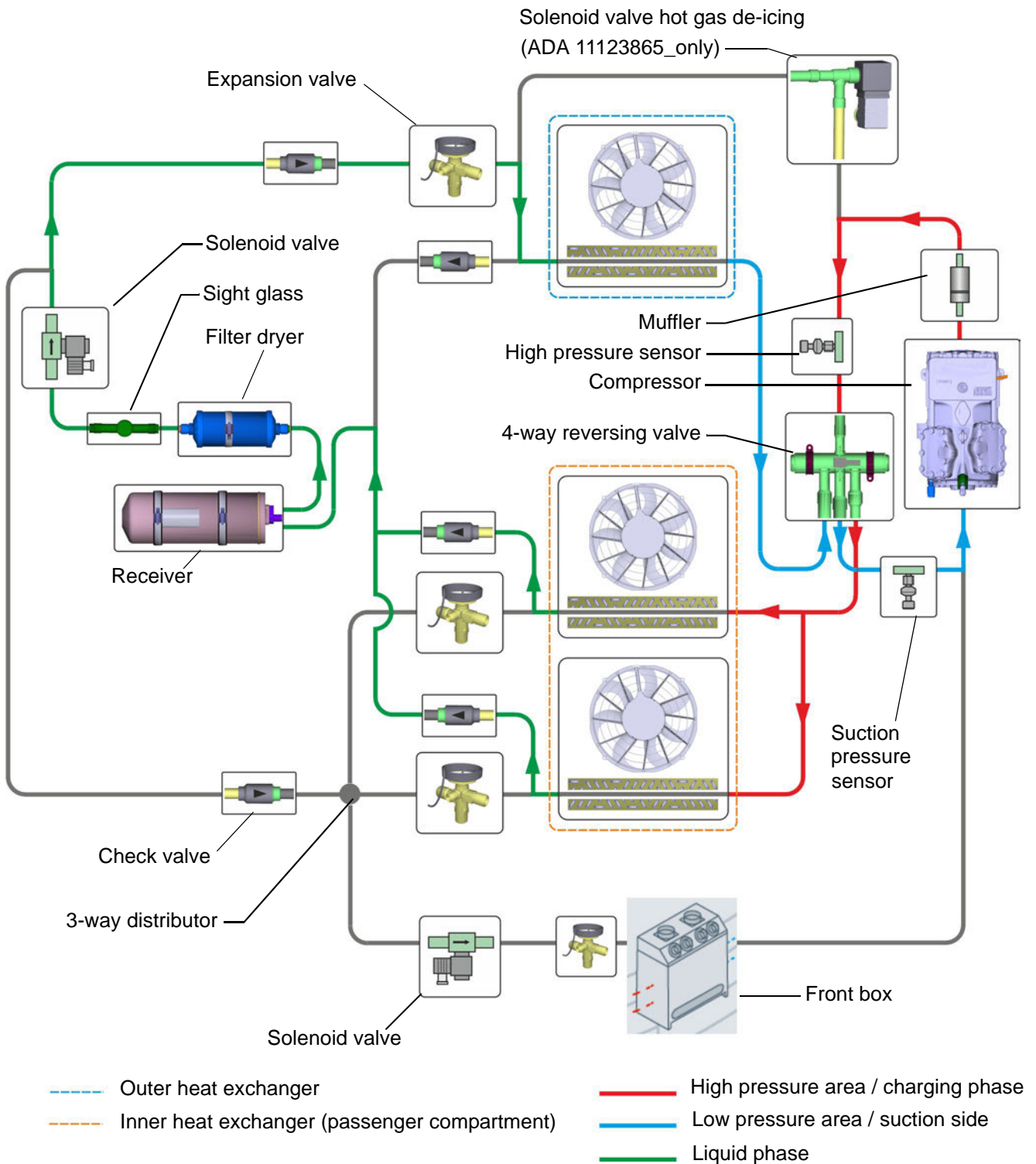

Fig. 414 Refrigerant circuit function schematic of the heat pump in the Heat Pump Mode

**4.5.3 4-way reversing valve function schematic**

Depending on the position, the 4-way reversing valve activates air conditioning or heat pump operation.

**4.5.3.1 Air conditioning mode**

See Fig. 415.

The 4-way reversing valve is in zero position (not switched). The system is working in air-conditioning mode.

**4.5.3.2 Heat Pump Mode**

See Abb. 416.

The 4-way reversing valve is in heat pump mode (switched). The system is in heat pump mode. The refrigerant circuit works in reverse.

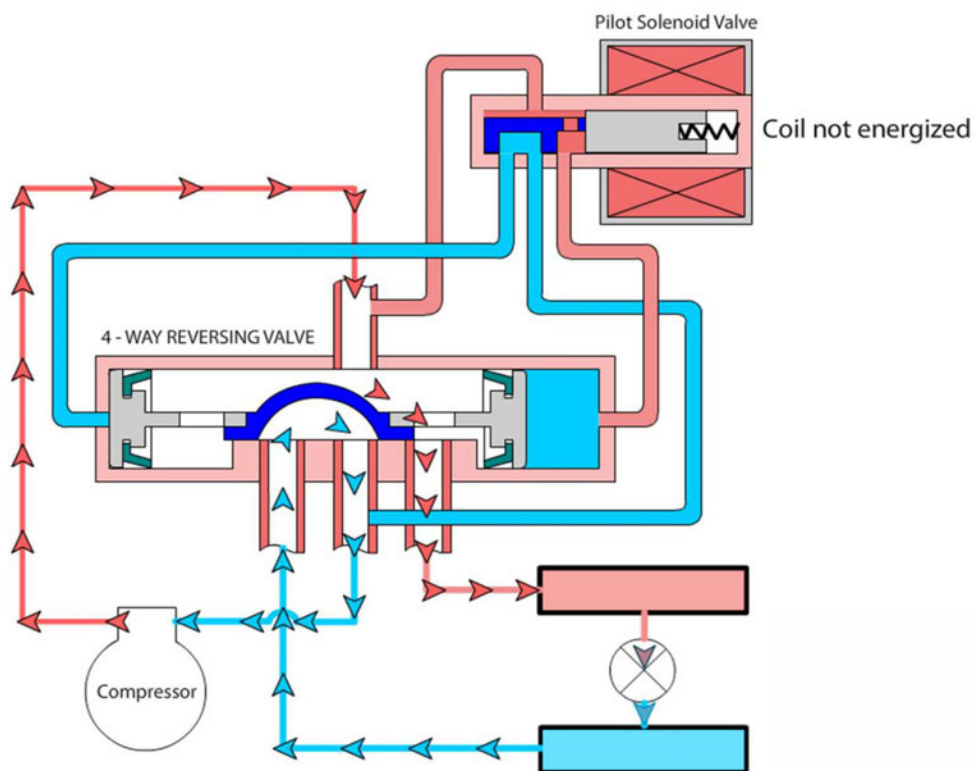

Ver. 09.10.23 • Danfoss A/S © Sep 2009

Fig. 415 Function of the 4-way reversing valve - air conditioning

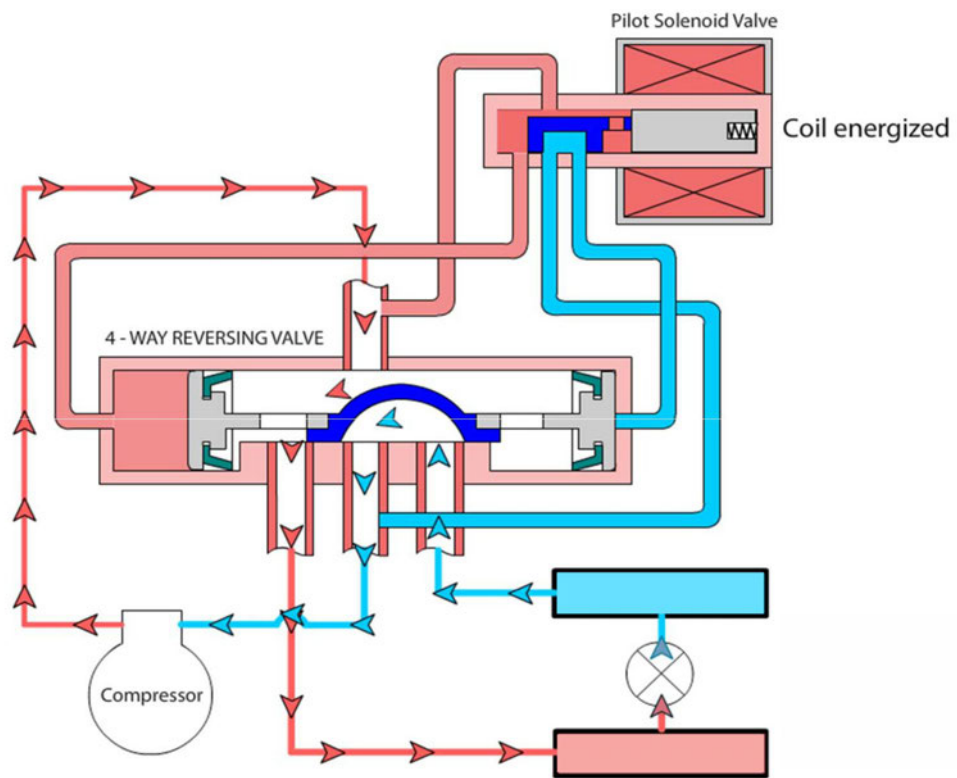

Ver. 09.10.23 • Danfoss A/S © Sep 2009

Abb. 416 Function of the 4-way reversing valve - Heat Pump Mode

4.5.4 Refrigerant circuit function schematic of the heat pump with hot gas de-icing (11123865\_ only)

This mode is only available with the 11123865\_ (additional solenoid valve) and allows the use of the system up to an outside temperature of -5°C.



Abb. 417 Refrigerant circuit function schematic of the heat pump with hot gas de-icing (11123865\_)

## 5 Troubleshooting

### 5.1 General

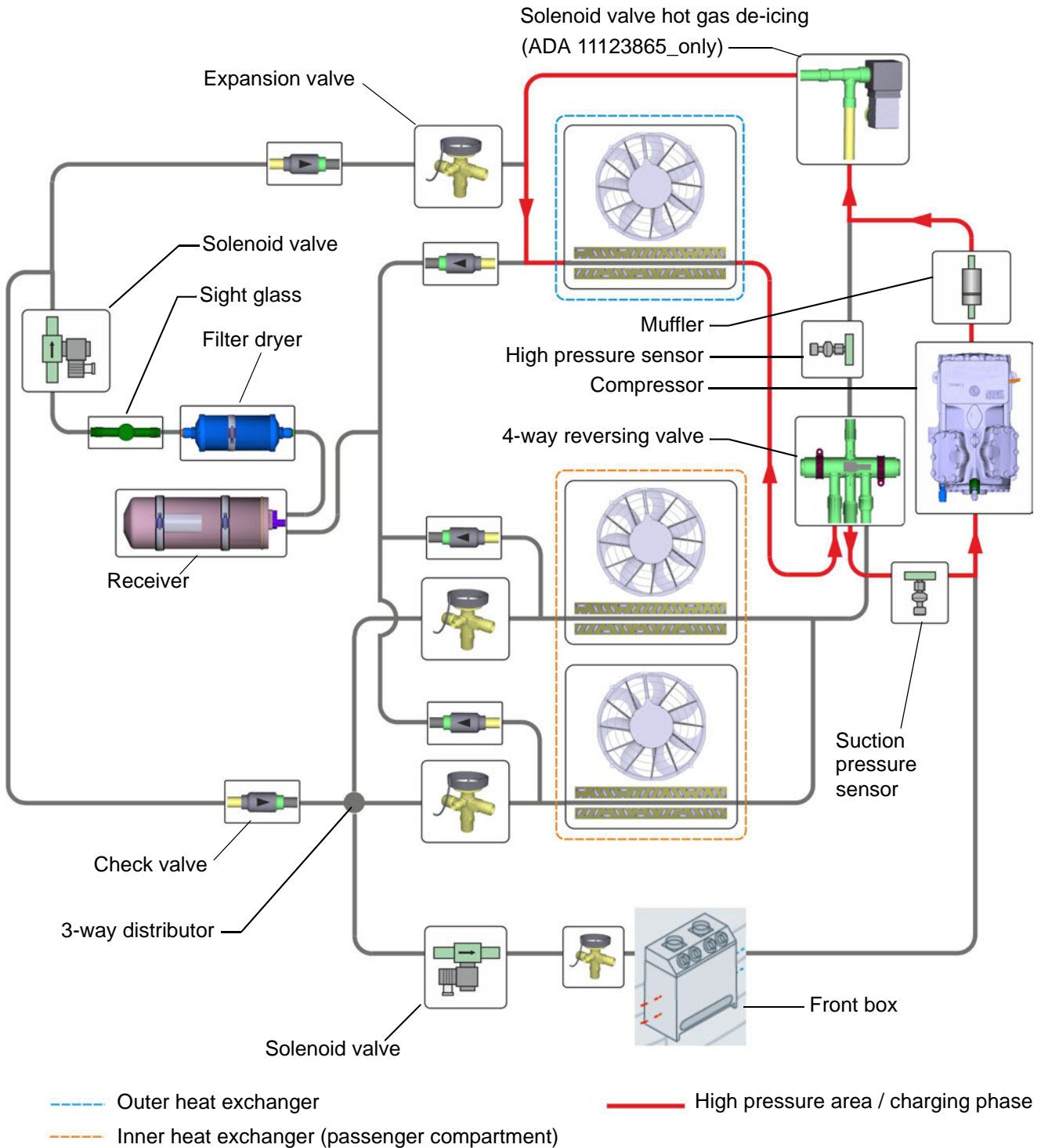

Follow the safety information and conditions from Chapter 1 (see 1.6).

This section describes how to look for and eliminate errors in the REVO-E air-conditioning system.

In the event of doubt, Chapters 3 and 4 contain the functional relationships.

When searching for errors and how to eliminate them, a systematic procedure is required. The corresponding measures for malfunctions of a general type or for deviations from desired conditions are to be implemented as described below.

### 5.2 Malfunctions in the air-conditioning circuit

#### 5.2.1 Causes of malfunctions in the air-conditioning system

- defective double radial blower or axial fan
- dirty or blocked air filter, dirty condenser or compressor fins
- refrigerant quantity not according to specification
- defective solenoid valve ADA or solenoid valve in the front box
- malfunctions in the expansion valve
- foreign gas in the refrigerant circuit
- insufficiently evacuated refrigerant circuit (final vacuum <10 mbar)

#### 5.2.2 What to do for malfunctions in the refrigerant circuit

If errors in the refrigerant circuit appear, the system must be inspected by a specialist and properly serviced. Do not allow the refrigerant to release into the atmosphere under any circumstances.

#### 5.2.3 Why the desired conditions are not reached when testing pressure

If deviations from the desired conditions are determined when testing the pressure, the following may have caused this.

Pressure is too high at the high-pressure manometer

- too low air flow rate at the heat exchanger (AC operation of outer heat exchanger / HP operation => inner heat exchanger)
- too much refrigerant

Pressure is too low at the high-pressure manometer

- too little refrigerant
- compressor speed too low (system in regular operation, maximum speed can be forced with the DCT component test)
- defective compressor

Verify and localize these causes, service or replace, as needed, defective parts.

### 5.3 Malfunctions in the electrical system

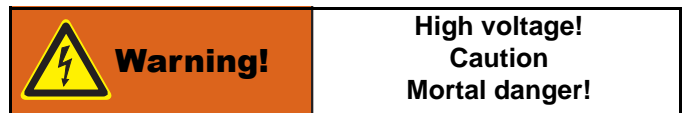

**Only conduct installation, maintenance and repair work if the motor is still and the 24V DC power supply as well as the high-voltage has been switched off.**

**Before starting work on the air-conditioning system, ensure that the system is voltage free and make sure it remains so for the duration of the work.**

**In certain cases, the following safety rules must be followed:**

- ensure the system is voltage free
- ensure system will not be reactivated
- verify system is voltage free
- ground and short-circuit
- cover or block off neighboring voltage-carrying parts

**Electrical work may only commence if protective measures against electrical shock, short-circuits and electric arcs have been taken.**

Chapter 4 contains the functional relationships when searching for errors.

Recognizing errors is normally limited to localizing the defective components. The following causes of malfunctions are not considered and should be verified and eliminated if a malfunction occurs for these reasons:

- corrosion on the plugs
- loose contact
- crimping errors on the plugs or pins
- corrosion on lines and fuses
- corrosion on the battery poles
- damage to the line insulation

**ATTENTION:**

**Search for malfunctions before replacing a fuse.**

**Separate the air-conditioning system from the vehicle's wiring system and replace the fuse while the system is powered down.**

**Install a fuse of the correct size (see Chapter 6 Wiring plan).**

Inspect the system's functionality after elimination of a malfunction in the vehicle.



## 5.4 Table of error codes

Table 501 Error codes

Valeo codes	Volvo ID	Error description
01	10911	ECU internal error
02	10912	PWM axial fan defective
03	10913	PWM double radial blower defective
04	10914	24V power supply too low
05	11554	External temperature signal not received >10s
06	11555	600V system status not received >10s
07	10917	Temperature of air duct / outlet temperature too high ( $T \geq 105^{\circ}\text{C}$ )
08	10918	Temperature of air duct / outlet temperature too low ( $T \leq -40^{\circ}\text{C}$ )
09	10919	Temperature of recirculated air / passenger cabin too high ( $T \geq 105^{\circ}\text{C}$ )
10	10920	Temperature of recirculated air / passenger cabin too low ( $T \leq -40^{\circ}\text{C}$ )
11	10921	Sensor value high pressure implausible high
12	11573	Sensor value high pressure implausible low
14	11536	Sensor value suction pressure implausible low
15	11542	System locked due to too many instances of high pressure
16	11569	System locked due to too many instances of low pressure
17	11543	Icing on heat exchanger (calculated via determination of suction pressure) *
18	10928	Common EDS (common error in electrical drive system)
20	11563	"Alternate charging status" signal not received
23	11560	"Maxpowerallowed" signal not received
24	11548	Inverter error
32	11325	HVIL error

\* In air conditioning mode only

In principle, we recommend the use of the diagnostic case with the diagnosis software Diagnosis Control Test DCT (see BA REVO-E Diagnostic). To diagnose the REVO-E heat pumps SW version 3.0 must be used. It is available for download on the website [www.valeo-thermalbus.com](http://www.valeo-thermalbus.com). Conceptually, inactive errors are only stored in the Volvo BEA-Body error memory and can only be read out or deleted there.

When using the Diagnosis Control Test DCT diagnostic software, ONLY active errors in the system are emphasized in red (e.g. **F01 – ECU internal**).

Below is a detailed description of the errors, with the associated test procedure and possible causes.



## 5.5 Error codes

### F01 ECU internal error

#### System behavior

- System not functioning & display off (GH) / LED not blinking
- or
- Display shows 'boot' and 'Err code'

#### Necessary inspections

- Test system using DCT
- Inspect the power supply of the SC620

#### Actions

- Replace SC620

### F02 PWM axial fan defective

#### System behavior

- Refrigerant compressor stops during Cooling Mode
- Axial fans do not run despite Cooling Mode being activated
- System in Ventilation Mode despite cooling demand from vehicle active

#### Necessary inspections

- Inspect axial fans. Use the DCT from the diagnostic case.
- Inspect cable harnesses according to wiring plan
- Force control of system via DCT test mode "Active with cooling"

#### Actions

- Replace SC620
- Replacing axial fans NOT necessary

### F03 PWM double radial blowers defective

#### System behavior

- Failure of all double radial blowers in system
- Refrigerant compressor stops during Cooling Mode
- System in Ventilation Mode despite cooling being required in vehicle

#### Necessary inspections

- Inspect double radial blowers. Use the DCT from the diagnostic case.
- Inspect cable harnesses according to wiring plan
- Force control of system via DCT test mode "Active with cooling"

#### Actions

- Replace SC620
- Replacing double radial blowers NOT necessary

### F04 24V power supply too low

#### System behavior

- double radial blowers not functioning
- Cooling Mode not functioning
- Power supply < 22V/ >10s

#### Necessary inspections

- Inspect 24V power supply (error active up to power supply >28V)

#### Actions

- Bus servicing necessary

### F05 External temperature signal not received >10s

#### System behavior

- Limited cooling function
- System in Cooling Mode

#### Necessary inspections

- Inspect external temperature sensor of bus
- Inspect CAN bus communication

#### Actions

- according to Volvo documentation

### F06 600V system status not received >10s

#### System behavior

- Limited cooling functionality
- System in Cooling Mode

#### Necessary inspections

- Inspect system with DCT component test
- Inspect CAN bus communication

#### Actions

- according to Volvo documentation

### F07 Temperature of air duct / outlet temperature too high ( $T \geq 105^{\circ}\text{C}$ )

#### System behavior

- Limited heating functionality

#### Necessary inspections

- Sensor values using DCT
- Sensor resistance on the sensor / to the SC620 plug (SC620 not connected) according to wiring plan

10kOhm	12.5kOhm	15.7kOhm
25°C	20°C	15°C

- Voltage present on sensor when SC620 and sensor plug connected

1.36V	1.5V	1.7V
25°C	20°C	15°C

**Actions**

- Measured values on sensor NOK => replace sensor
- Measured values on cable harness (SC620 side) NOK => inspects pin / replace cable harness
- Measured values on cable harness (SC620 side) OK => replace SC620

**F08 Temperature of air duct / outlet temperature too low (T<= -40°C)**

**System behavior**

- Limited heating functionality

**Necessary inspections**

- Sensor values using DCT
- Sensor resistance on the sensor / to the SC620 plug (SC620 not connected) according to wiring plan  
10kOhm 12.5kOhm 15.7kOhm  
25°C 20°C 15°C
- Voltage present on sensor when SC620 and sensor plug connected

1.36V	1.5V	1.7V
25°C	20°C	15°C

**Actions**

- Measured values on sensor NOK => replace sensor
- Measured values on cable harness (SC620 side) NOK => inspects pin / replace cable harness
- Measured values on cable harness (SC620 side) OK => replace SC620

**F09 Temperature of recirculated air / passenger cabin too high (T≥ 105°C)**

**System behavior**

- Limited heating functionality
- Limited cooling functionality

**Necessary inspections**

- Sensor values using DCT
- Sensor resistance on the sensor / to the SC620 plug (SC620 not connected) according to wiring plan  
10kOhm 12.5kOhm 15.7kOhm  
25°C 20°C 15°C
- Voltage present on sensor (SC620 / sensor plug connected)

1.36V	1.5V	1.7V
25°C	20°C	15°C

**Actions**

- Measured values on sensor NOK => replace sensor
- Measured values on SC620 plug NOK => inspect pins / replace cable harness
- Measured values on cable harness SC620 side OK => replace SC620

**F10 Temperature of recirculated air / passenger cabin too low (T<= -40°C)**

**System behavior**

- Limited cooling functionality
- System in Cooling Mode

**Necessary inspections**

- Sensor values using DCT
- Sensor resistance on the sensor / to the SC620 plug (SC620 not connected) according to wiring plan  
10kOhm 12.5kOhm 15.7kOhm  
25°C 20°C 15°C
- Voltage present on sensor (SC620 / sensor plug connected)  
1.36V 1.5V 1.7V  
25°C 20°C 15°C

**Actions**

- Measured values on sensor NOK => replace sensor
- Measured values on SC620 plug NOK => inspect pins / replace cable harness
- Measured values on cable harness SC620 side OK => replace SC620

**F11 Sensor value high pressure implausible high (evaluation of sensor signal) (measured value Pabs > 26bar)**

**System behavior**

- Error occurs after multiple switching of the high-pressure safety switch
- only in combination with F18

In Cooling Mode:

- default value high pressure 20bar
- axial fans maximum speed

In Heat Pump Mode:

- radial blowers maximum speed
- compressor minimum speed

**Necessary inspections**

- Sensor values using DCT
- Check pressure with pressure gauge and calibrate with sensor values (Attention: sensor values are absolute values)
- Sensor resistance 5.4kOhm on the sensor / to the SC620 plug (SC620 not connected) according to wiring plan when compressor has not been functioning for long period of time
- Voltage present on sensor (SC620 / sensor plug connected) when system running  
~7.4bar ~6.4bar  
1.36V 1.5V  
When compressor has been off for a longer time  
1.7V at 15°C

**Actions**

- Measured values on sensor NOK => replace sensor
- Measured values on SC620 plug NOK => inspect pins / replace cable harness
- Measured values on cable harness SC620 side OK => replace SC620

**F12 Sensor value high pressure implausible low (evaluation of sensor signal) (measured value Pabs < 0bar)**

**System behavior**

- Error occurs after multiple switching of the low-pressure safety switch (at 11123865\_ virtual via software)
- only in combination with F18

## In Cooling Mode:

- default value high pressure 20bar
- axial fans maximum speed

## In Heat Pump Mode:

- radial blowers maximum speed
- compressor minimum speed

**Necessary inspections**

- Sensor values using DCT
- Check pressure with pressure gauge and calibrate with sensor values (Attention: sensor values are absolute values)
- Sensor resistance 5.4kOhm on the sensor / to the SC620 plug (SC620 not connected) according to wiring plan when compressor has not been functioning for long period of time
- Voltage present on sensor (SC620 / sensor plug connected) when system running  
~7.4bar    ~6.4bar  
1.36V    1.5V  
When compressor has been off for a longer time  
1.7V at 15°C

**Actions**

- Measured values on sensor NOK => replace sensor
- Measured values on SC620 plug NOK => inspects pin / replace cable harness
- Measured values on cable harness SC620 side OK => replace SC620

**F14 Sensor value suction pressure implausible low (evaluation of sensor signal) (measured value Pabs < 0bar)**

**System behavior**

- default value 0.5bar => compressor off
- that means below the threshold low pressure
- error entry F12 + F18

**Necessary inspections**

- Sensor values using DCT (operating >2 bar)

- Check pressure with pressure gauge and calibrate with sensor values (Attention: sensor values are absolute values)
- Plug connection to sensor
- Measurements on X854 plug
  - Sensor power supply (5V)
  - Sensor voltage (feedback) when compressor deactivated
  - Sensor voltage (feedback) when compressor deactivated (2V-4V)
 Note: Compressor controllable using DCT components test.

**Actions**

- Replace cable harness or SC620
- Replace sensor

**F15 System locked due to too many instances of high pressure**

**System behavior**

- System locked due to too many instances of high pressure (5x)
- Error only in combination with F18

**Necessary inspections**

- Sensor values using DCT (after first unlocking system)
- If high pressure error + axial fan speed high
  - Air flow at condenser (dirty condenser)
  - Amount of refrigerant (according to Volvo documentation)
- If high pressure error + axial fan speed low
  - Comparison of sensor value DCT with high-pressure system measured with manometer

**Actions**

- To unlock the system, press the Gas Charging button (above driver) for at least 15 s. System can then be inspected.
- Clean heat exchanger fins
- Refill according to Volvo documentation
- Replace sensor

**F16 System locked due to too many instances of low pressure**

**System behavior**

- SW low-pressure safety switch triggers => P<1.2bara for >22 s
- After 3 times low pressure event, system locked
- Error only in combination with F18

**Necessary inspections**

- Sensor values using DCT (after unlocking the system first)
- Solenoid valve with DCT components test (acoustic)

- Voltage at the solenoid valve 0V= closed / 24V open
  - Pressure level in low pressure range using manometer when compressor >2 bar - expansion valve OK
  - Suction pressure sensor on X854 plug
    - Power supply of the connected sensor (5V)
    - Sensor voltage (feedback) when compressor deactivated
    - Sensor voltage (feedback) when compressor deactivated (2V-4V)
- Note: Compressor controllable using DCT components test.

**Actions**

- Unlocking the system: Press and hold for at least 15 sec. the gas charging button (above the driver). See vehicle documentation. System can then be inspected.
- Replace solenoid valve
- Replace expansion valve or refill according to Volvo documentation
- Replace suction pressure sensor

**F17 Icing on the inner heat exchangers in Cooling Mode**

**System behavior** (in Air-conditioning Mode possible only)

- Cooling functionality temporarily limited / air-conditioning system in Ventilation Mode
- Compressor turned off until deiced (<2 bar absolute pressure for at least 15s)

**Necessary inspections**

- Sensor values using DCT
- Visually inspect icing on the evaporator
- Visually inspect contamination of fresh air filter
- Expansion valve (suction pressure >2 bar)
- Refrigerant level

**Actions**

- Defrost evaporator
- Replace fresh air filter
- Replace expansion valve(s)
- Refill according to Volvo documentation

**F18 Common error in EDS (Electrical Drive System)****System behavior**

- Compressor does not start
  - Red LED of frequency converter is blinking
- Note: No common problem of the frequency converter

**Necessary inspections**

- Sensor values using DCT
- Only relevant in connection with other errors
- Inspect high pressure safety switch

- Inspect low pressure safety switch
- Read off from error memory of frequency converter (handheld reader / PC diagnostic)
- Insulation test signal line frequency converter against its housing

**Actions**

- Eliminate error depending on other errors entered
- Eliminate error in frequency converter according to EPA description (see OI REVO-E Diagnostics)

**F20 "Alternate charging status" signal not received****System behavior**

- Limited cooling functionality - Ventilation Mode

**Necessary inspections**

- Vehicle system
- CAN bus communication

**Actions**

- Eliminate error according to vehicle documentation

**F23 "Maxpowerallowed" signal not received****System behavior**

- Compressor runs without limitations, sometimes very high power usage

**Necessary inspections**

- Vehicle system
- CAN bus communication

**Actions**

- Eliminate error according to vehicle documentation

**F24 Frequency converter / inverter error****System behavior**

- System locked - system in Ventilation Mode
  - Error entry after 10x F18 (Common EDS)
- Note: without simultaneous high or low pressure event (other FS)

**Necessary inspections**

- Sensor values using DCT
- Read off from error memory of frequency converter (handheld reader / PC diagnostic)
- Safety chain (high / low pressure safety switch / frequency converter)
  - Continuity test of X854 plug Pin3 and Pin11
  - Individual components of safety chain (pressure switch)

**Actions**

- Replace pressure switch

- Eliminate error in frequency converter according to EPA description (see operating instructions of diagnostics case)

Unlock - ignition off and wait 1 min

### **F32 HVIL error**

#### **System behavior**

- Cooling Mode not available

#### **Necessary inspections**

- HVIL power using DCT (13-19 mA)
- Other high-voltage components affected in vehicle
- HVIL "loop" in the air-conditioning system according to wiring plan
- HVIL resistance in the system (~10 Ohm)
- HVIL resistance of system + cable harness (SC620 separated) ~11 Ohm
- HVIL power supply for vehicle according to vehicle documentation

#### **Actions**

- Replace cable harness
- Replace SC620
- Repair according to Volvo documentation

There are two options for the diagnosis of the frequency converter:

1. MMI handheld control device  
This is sufficient for reading the fault memory, but without precise information about the time.  
=> Read out current errors of the frequency converter  
=> Read out error memory (inactive errors) of the frequency converter
2. Analysis via PC (recommended)  
The expert-level diagnosis (detailed information of the frequency converter control) can be carried out by means of the manufacturer diagnostic software. This is part of the DCT setup file (data CD).  
=> Read out current errors  
=> Read out the last 20 errors of the frequency converter ("Time course" field)  
=> All errors over lifetime incl. counter ("Counter" field)  
=> Read out operating hours (600V DC power supply)  
=> Possible to record data

In both cases, the frequency converter must be provided with 600V DC. Hybrid system must be active.

### 5.6 Inspecting functionality of individual components

The inspection of individual components may take the form of a visual inspection or manual electric inspection. In addition, electrical components can be inspected using the DCT components test. A compilation of these can be found in [Table 503](#).

Details can be found in "OI REVO-E Diagnostics" Chap. 3.5 Diagnosis Control Test.

Table 503

Components	Measured values	Measurement steps
Axial fans	Speed	0%/ 50%/ 80%/ 100%
Double radial blowers	Speed	0%/ 50%/ 80%/ 100%
Compressor <sup>1)</sup>	Speed	32%/ 50%/ 100%
Solenoid valve	Position	Open / closed
Low pressure switch <sup>1), 2)</sup>	Position	Switched off
High pressure switch <sup>1), 3)</sup>	Position	Switched off
Position of air valves	Position	Fresh air / recirculating air
4-way reversing valve	Position	Heat Pump / Cooling
Valve de-icing	Position	Open / closed

- 1) When switching off compressor, error F18 will be marked for 1 min.
- 2) Adjustment forces system into low pressure range until shut off.
- 3) Adjustment forces system into high pressure range until shut off.

#### 5.6.1 General visual inspection

- Inspect components for damage (cracks, deformation, seal, discoloration, etc.) and replace, as needed.
- Inspect plugs and lines for corrosion, (loss of) contact, crimping errors, etc. and repair, as needed.
- Inspect plug contacts for corrosion and proper seating, repair as needed.
- Visually examine all electric lines (high and low voltage) for abrasion

### 5.7 Diagnosing the REVO-E units using the Diagnosis Control Test – DCT diagnostic software

Information about this can be found in the operating instructions "OI REVO-E Diagnostics", Chap. 4.

### 5.8 Diagnosing the frequency converter

Information about this can be found in the operating instructions "OI REVO-E Diagnostics", Chap. 5 / Attachment EPA instructions for searching for errors.

## 6 Wiring diagrams

The chapter contains the wiring diagram and fuse assignment for the following systems:

- REVO-E Heat Pump
- Electrical connections electrical components

### NOTE:

For the wiring diagram, keep in mind:

- All lines without information on the cross-section have  $A=0.75\text{mm}^2$
- Lines without color information = white
- Illustrations are generally without power or pressure

### 6.1 Electrical fuses

REVO-E Heat Pump:

Secured components	Fuse	Fuse value
Double radial blower right	F1	15
Double radial blower right	F2	15
Double radial blower right	F3	15
Double radial blower left	F4	15
Double radial blower left	F5	15
Double radial blower left	F6	15
Axial fan	F7	20
Axial fan	F8	20
Axial fan	F9	20

### 6.2 Wiring diagram REVO-E HP (11120816\*)

Fig. 601 (pages 1 - 6) includes the wiring diagram for the REVO-E HP



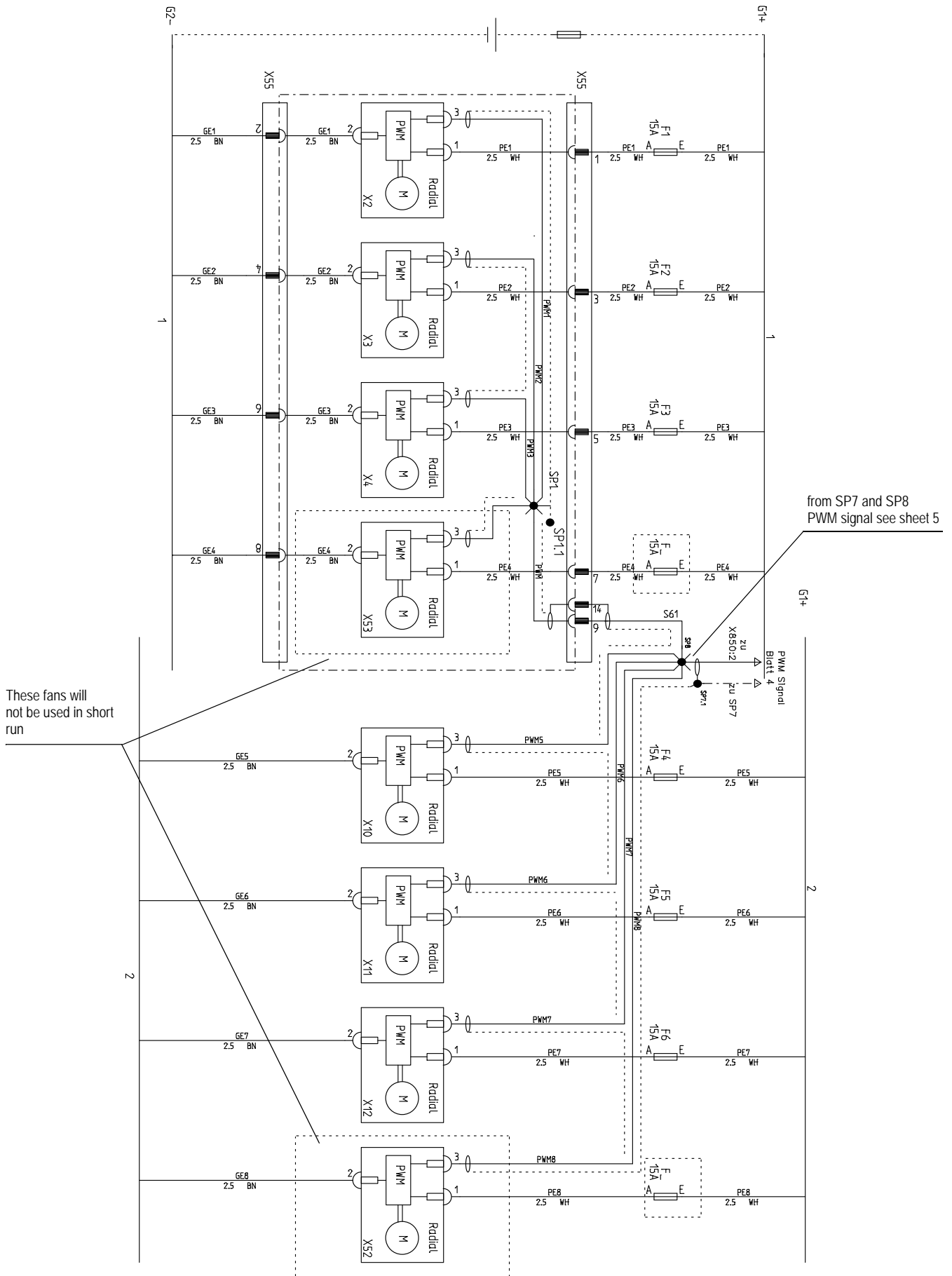

Fig. 601 Wiring diagram for REVO-E HP (Sheet 1)

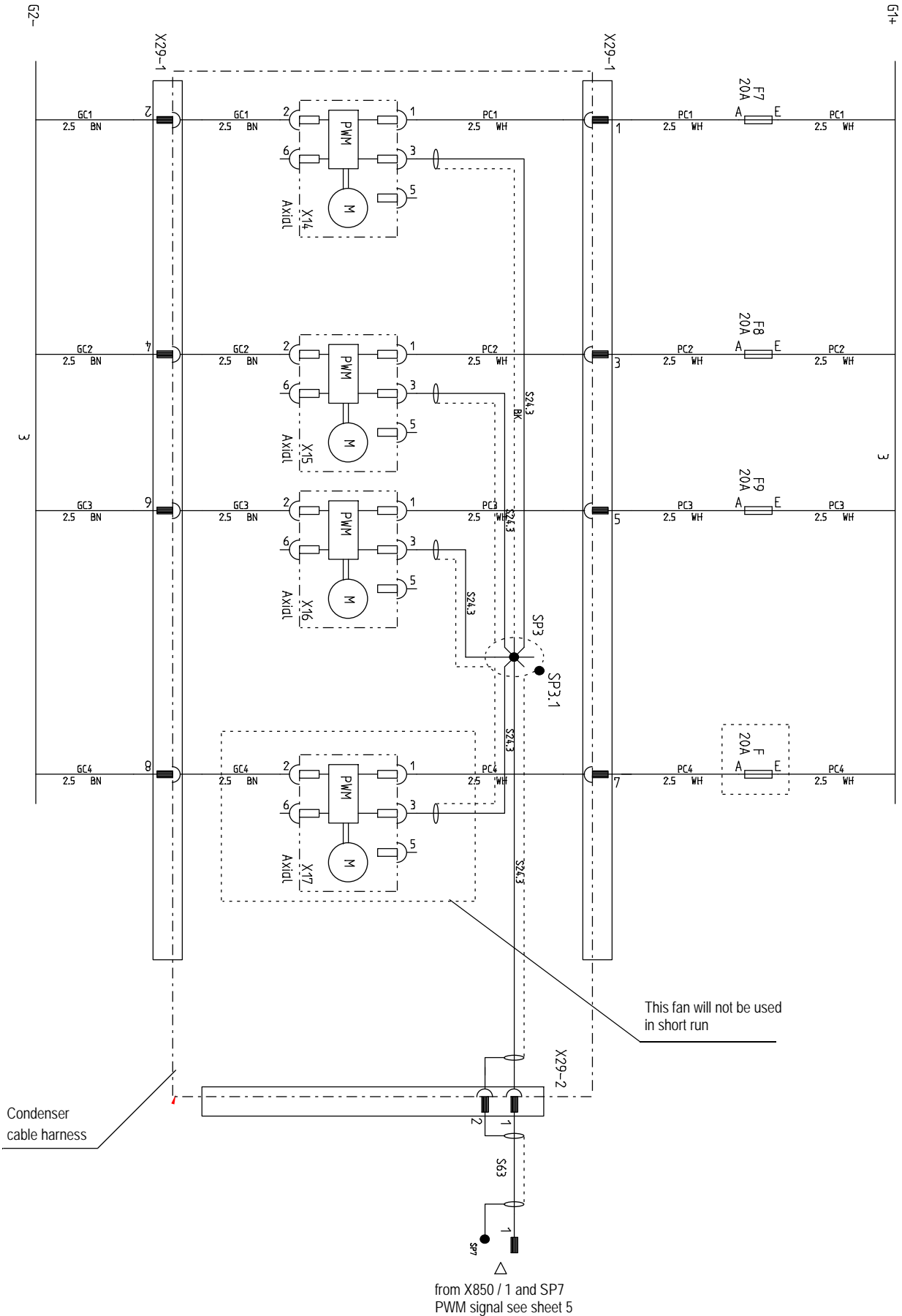

Fig. 601 Wiring diagram for REVO-E HP (Sheet 2)

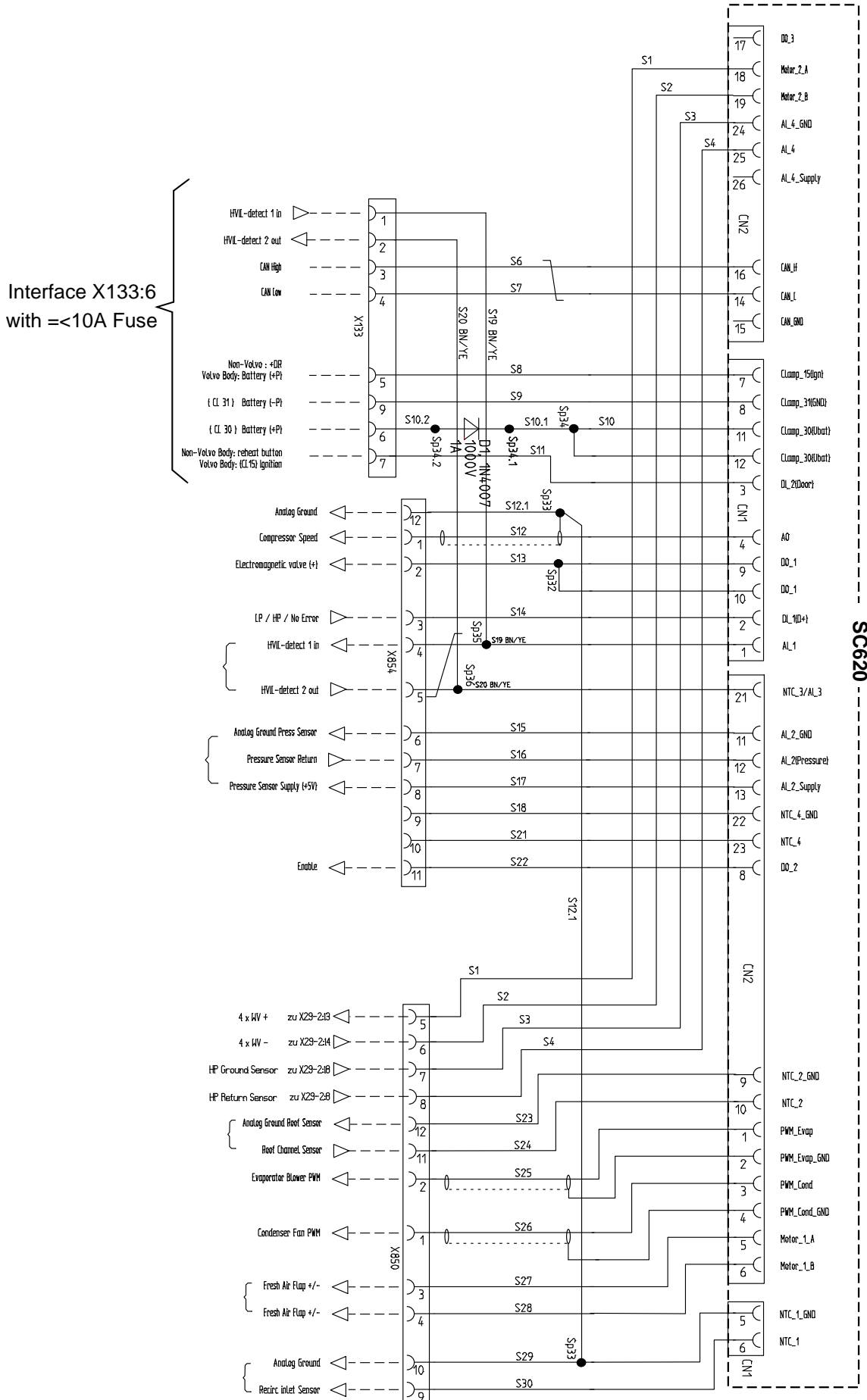

Fig. 601 Wiring diagram for REVO-E HP (Sheet 3)

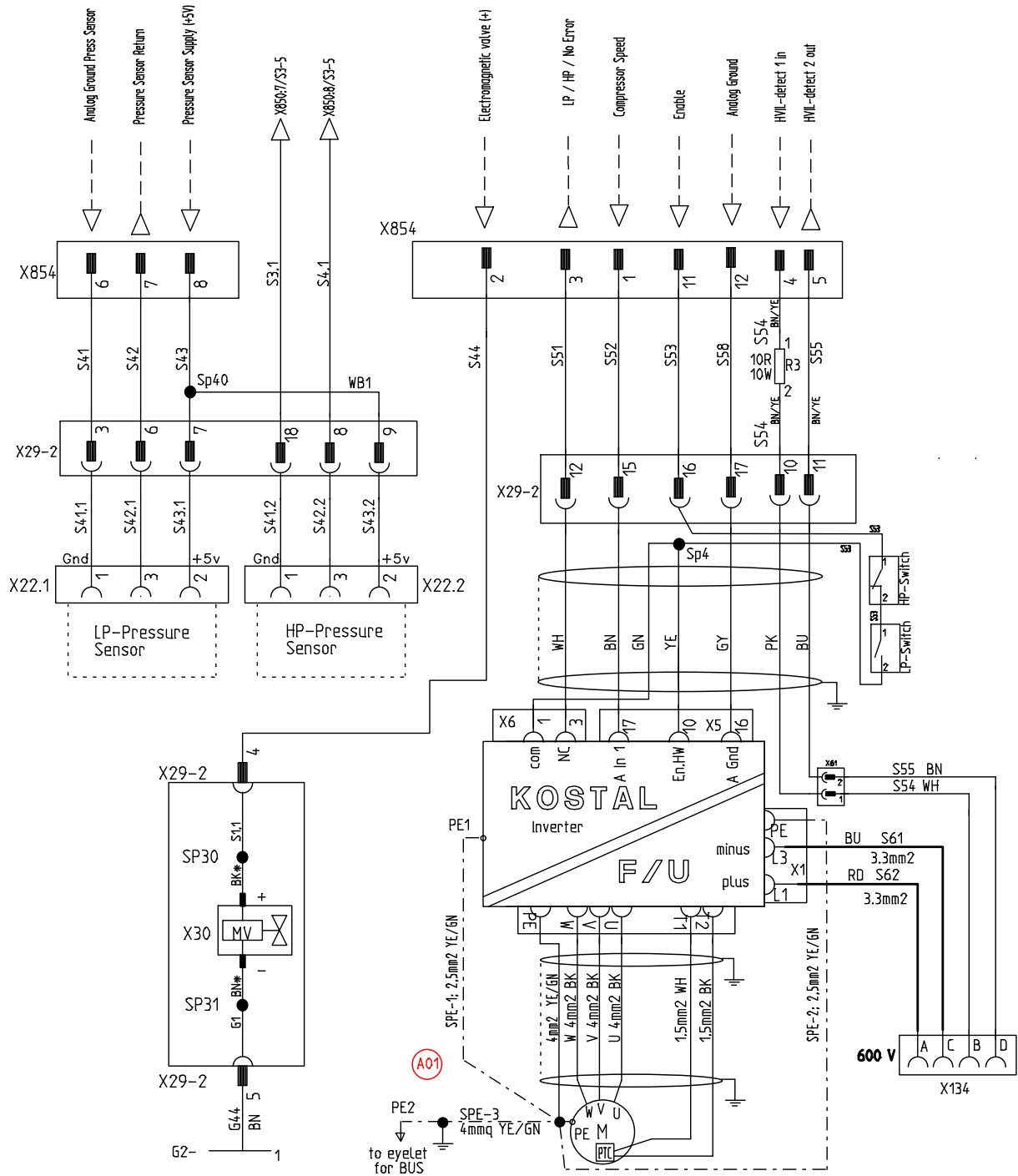

Fig. 601 Wiring diagram for REVO-E HP (Sheet 4)

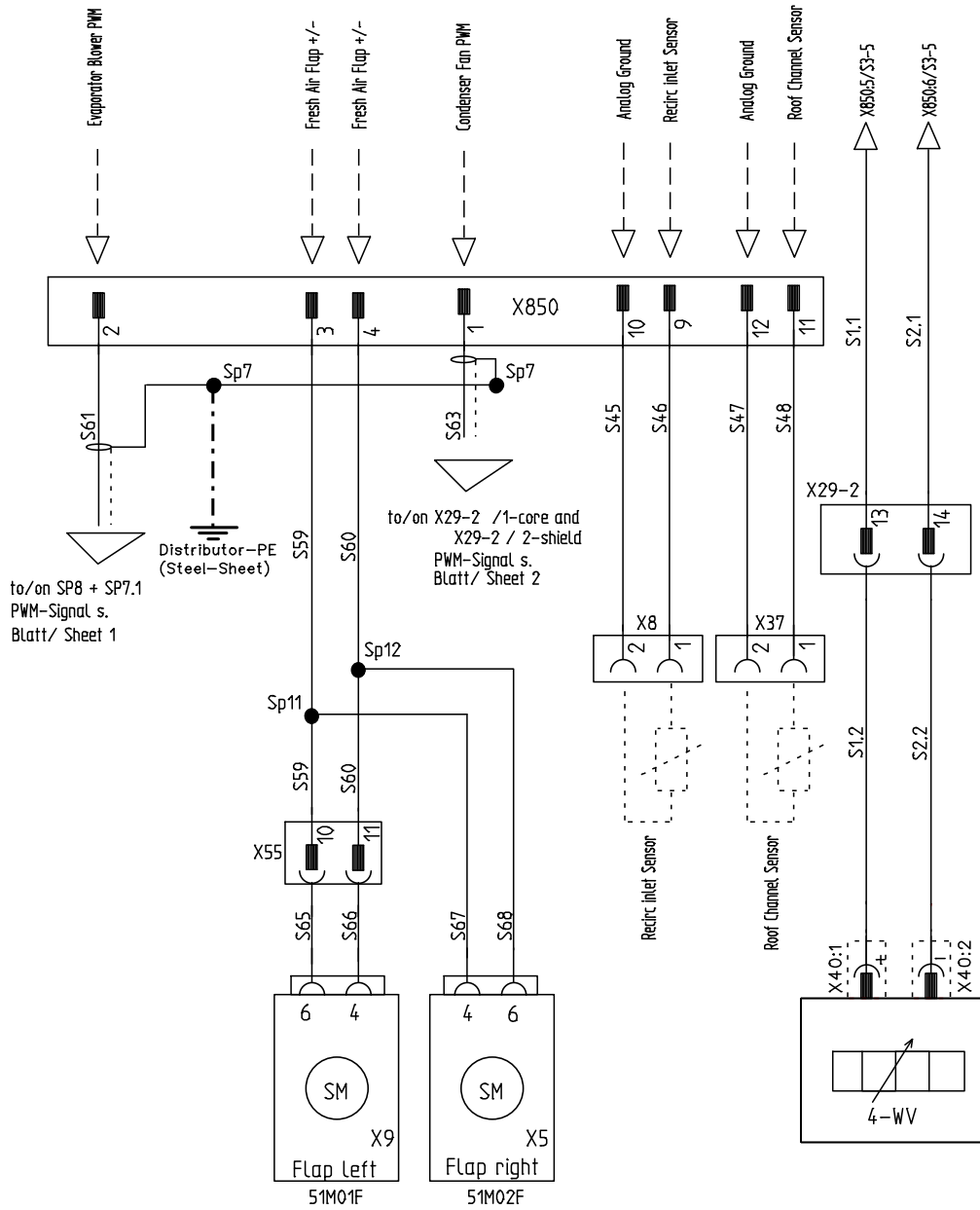
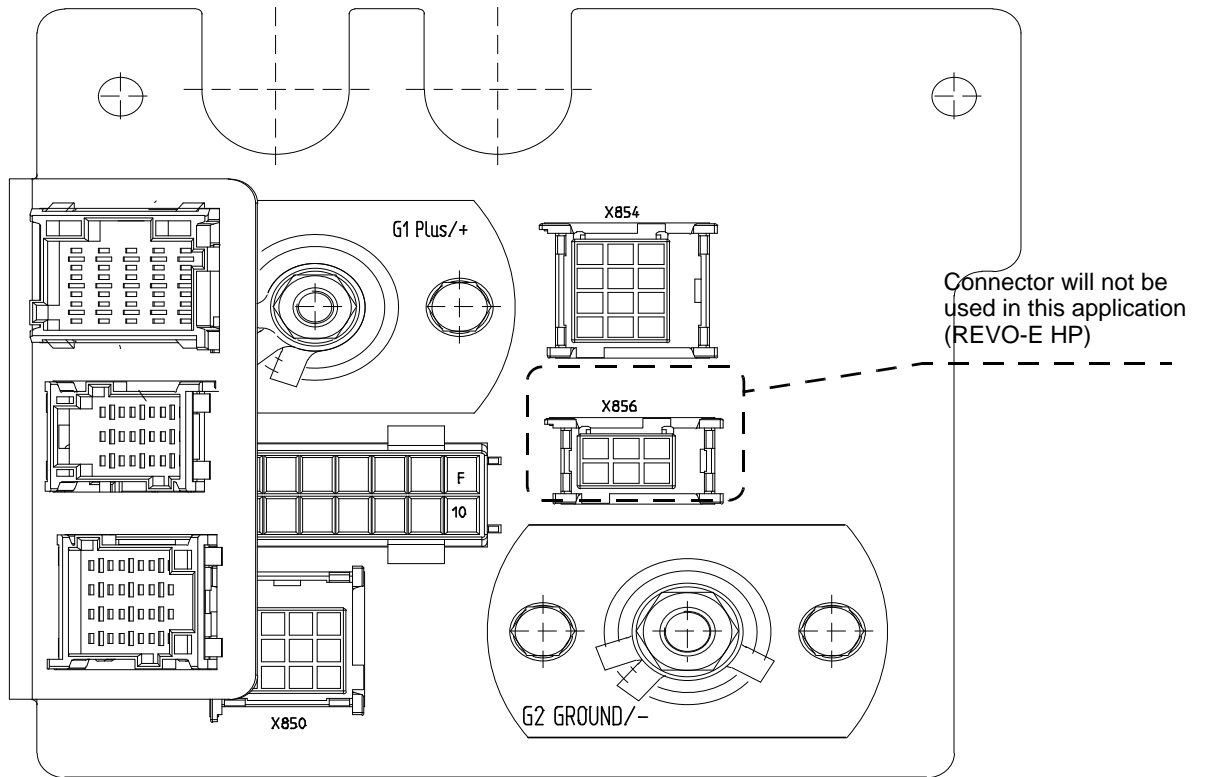

Fig. 601 Wiring diagram for REVO-E HP (Sheet 5)



Connector pin assignment		
Pin	X854	X850
1	Compressor Speed	Condenser Fan PWM
2	Electromagnetic valve (+)	Evaporator Blower PWM
3	LP/HP/Drive Error	Fresh Air Flap +/-
4	HVIL - detect 1 in	Fresh Air Flap +/-
5	HVIL detect 2 out	WV+
6	Analog Ground Press Sensor	WV-
7	Pressure Sensor Return	HP GND
8	Pressure Sensor Supply (+5V)	HP Return
9	Analog Ground	Recirc inlet Sensor
10	Cooling Liquid Temp Sensor	Analog Ground
11	Enable	Roof Channel Sensor
12	Analog Ground	Analog Ground

Fig. 601 Wiring diagram for REVO-E HP (Sheet 6)

### 6.3 Wiring diagram REVO-E HP+ (11123865\*)

Fig. 602 (pages 1 - 6) includes the wiring diagram for the REVO-E HP+.



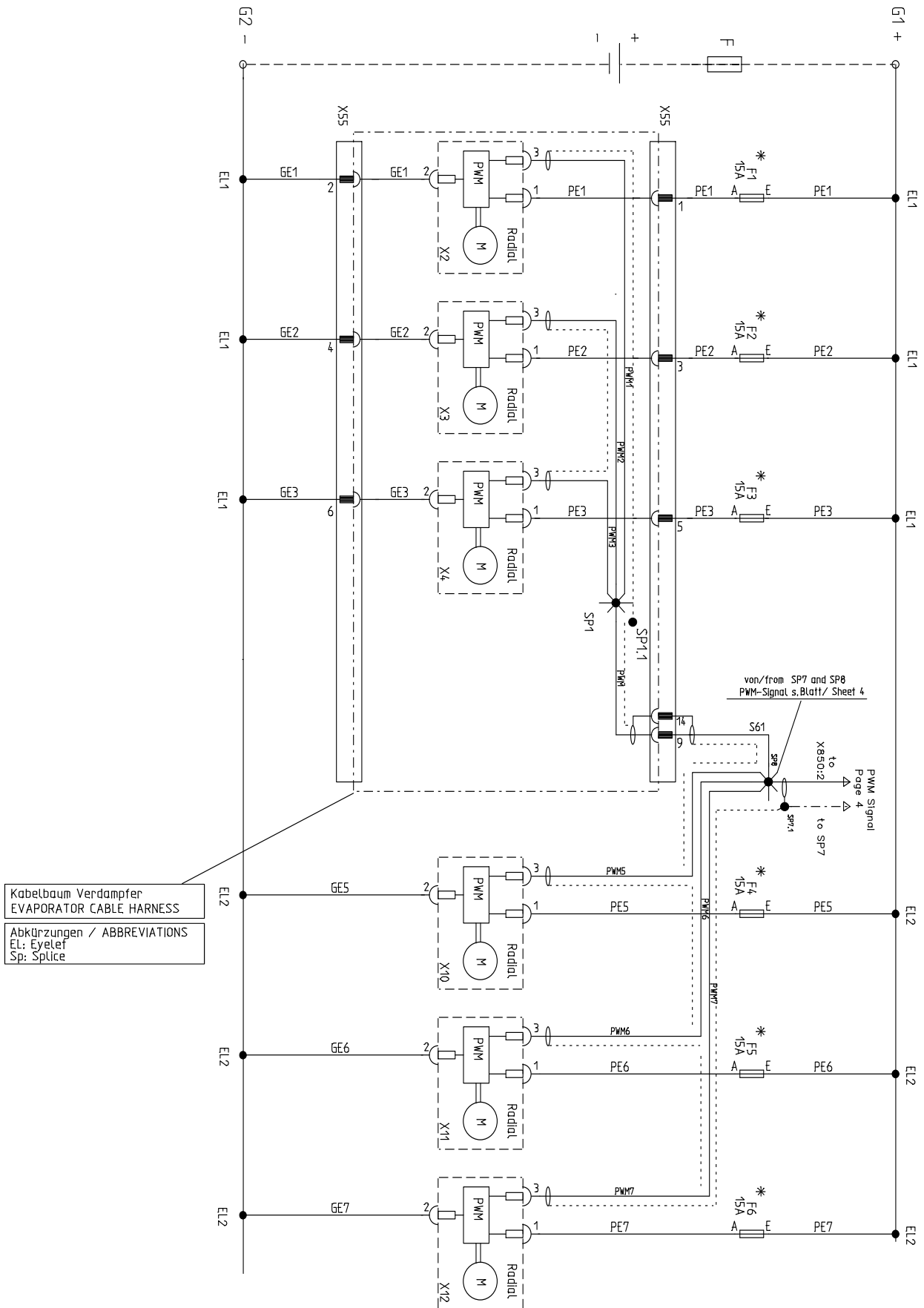

Fig. 602 Wiring diagram for REVO-E HP+ (Sheet 1)

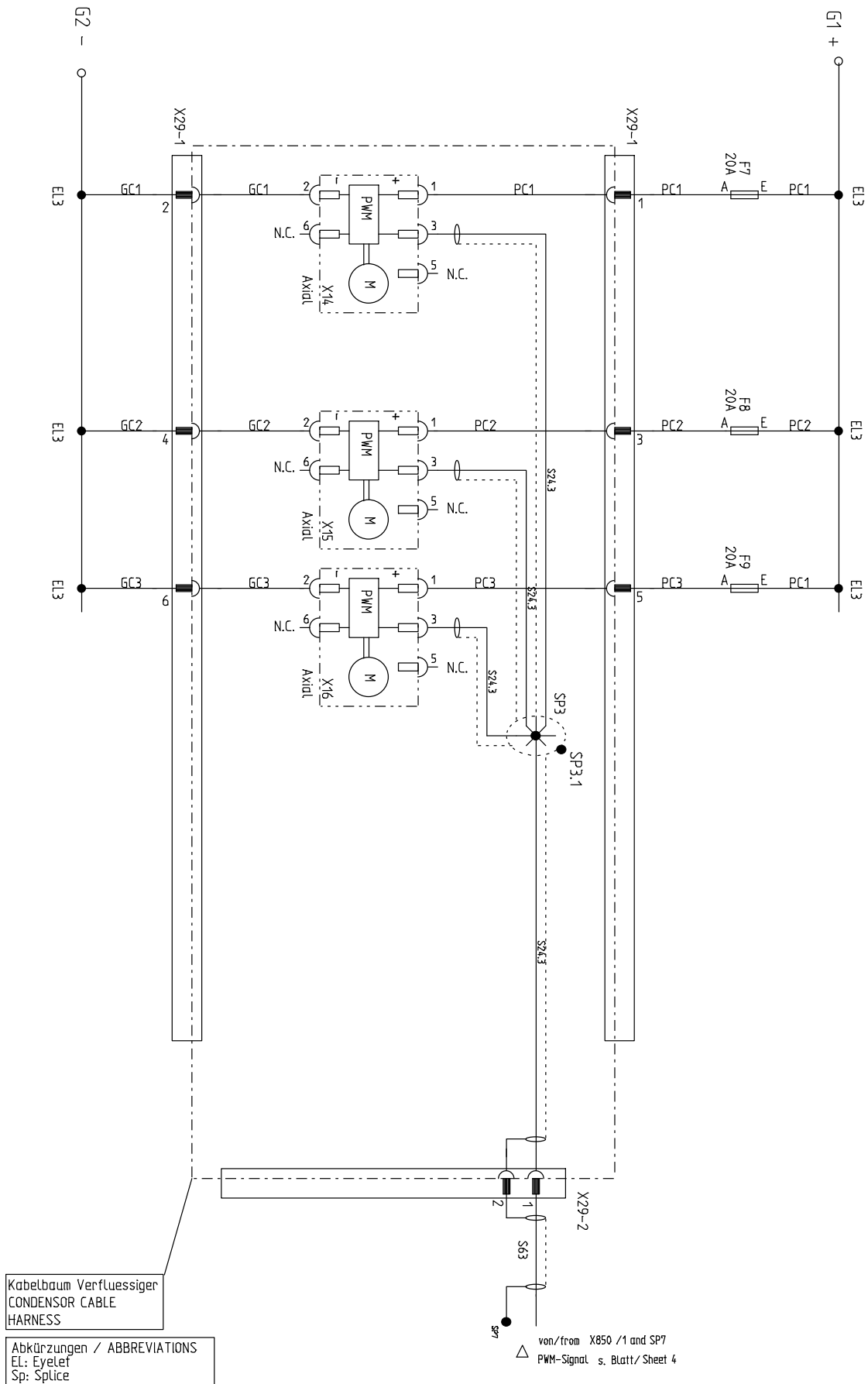

Fig. 602 Wiring diagram for REVO-E HP+ (Sheet 2)

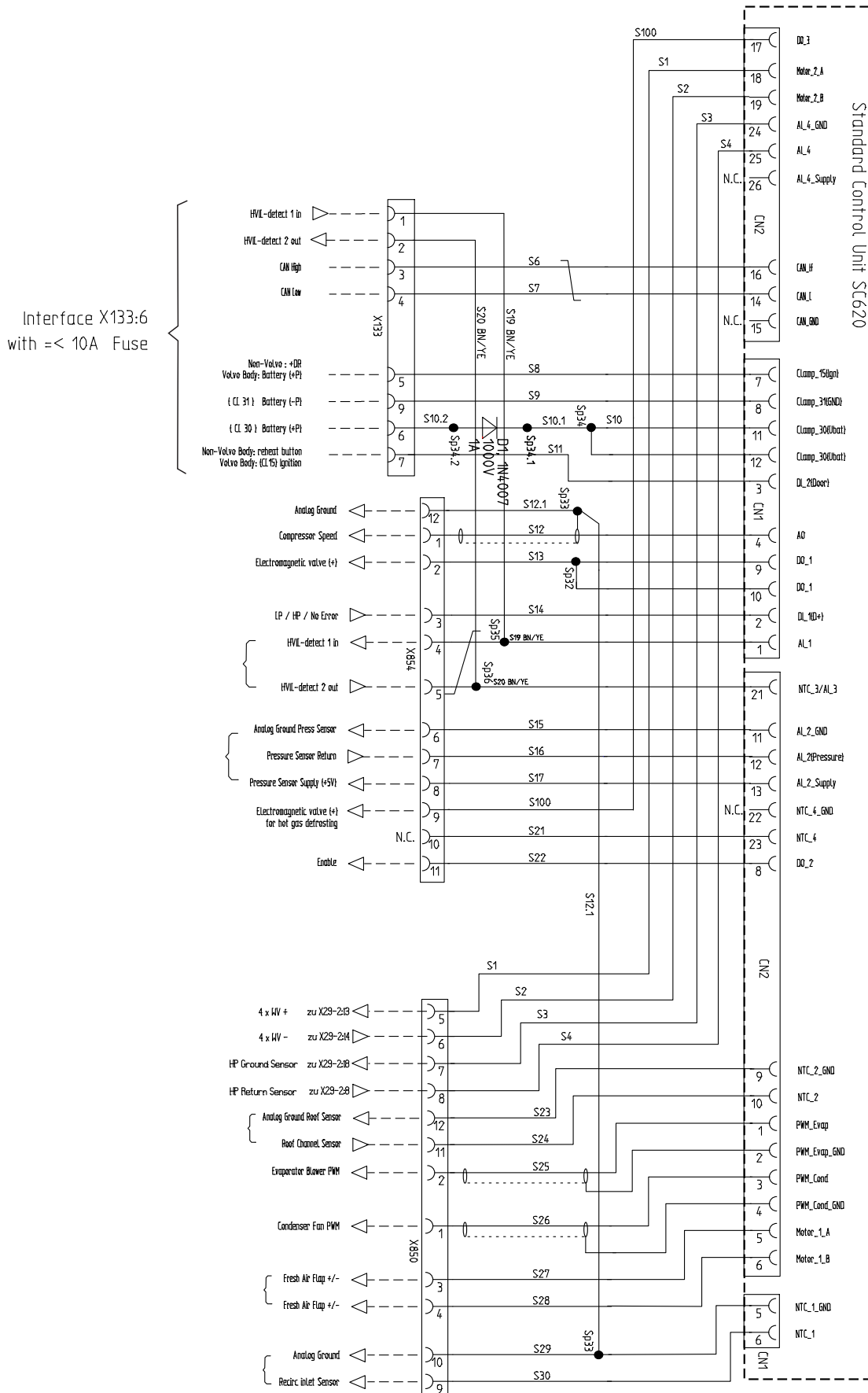

Fig. 602 Wiring diagram for REVO-E HP+ (Sheet 3)

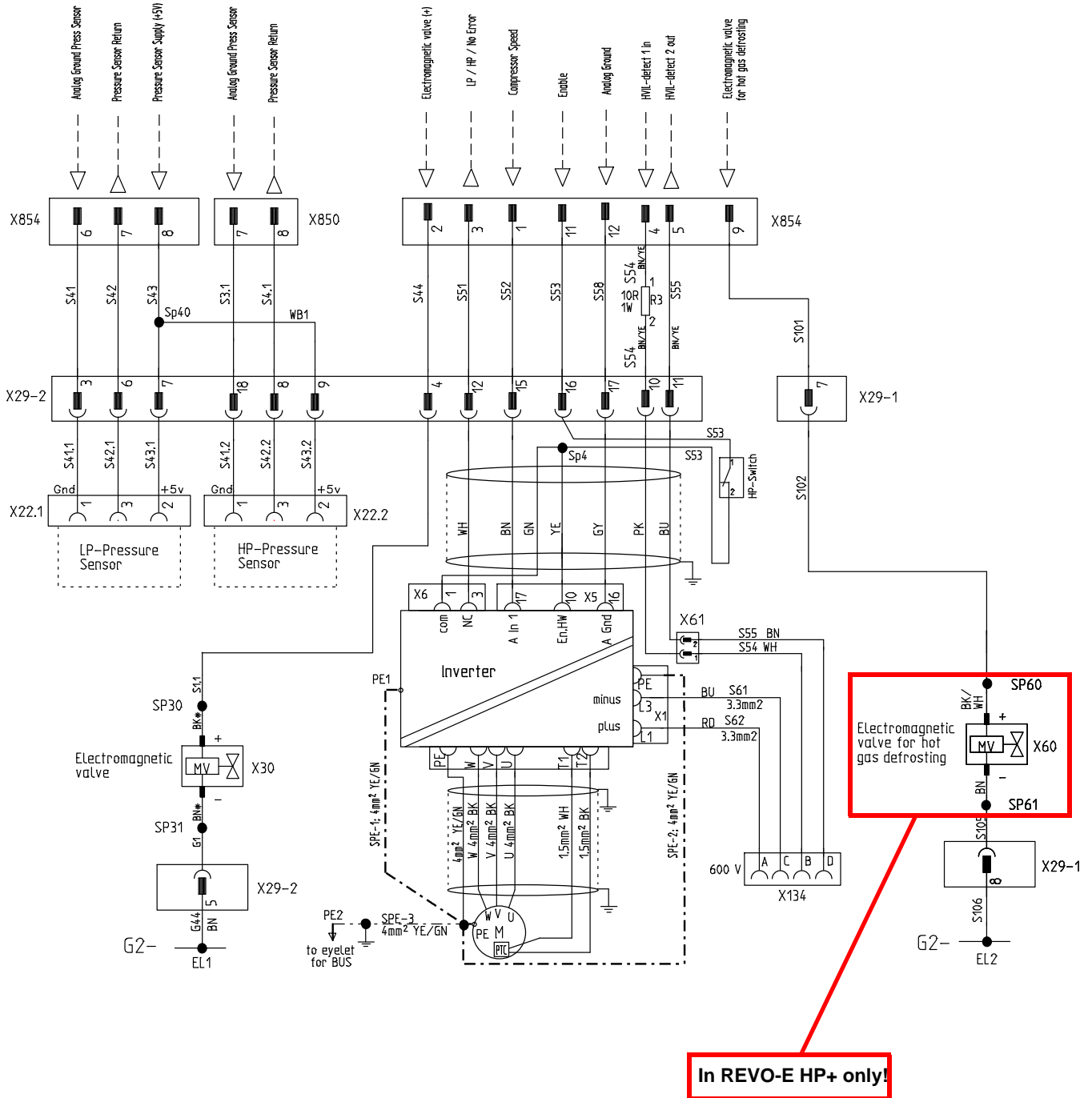

Fig. 602 Wiring diagram for REVO-E HP+ (Sheet 4)

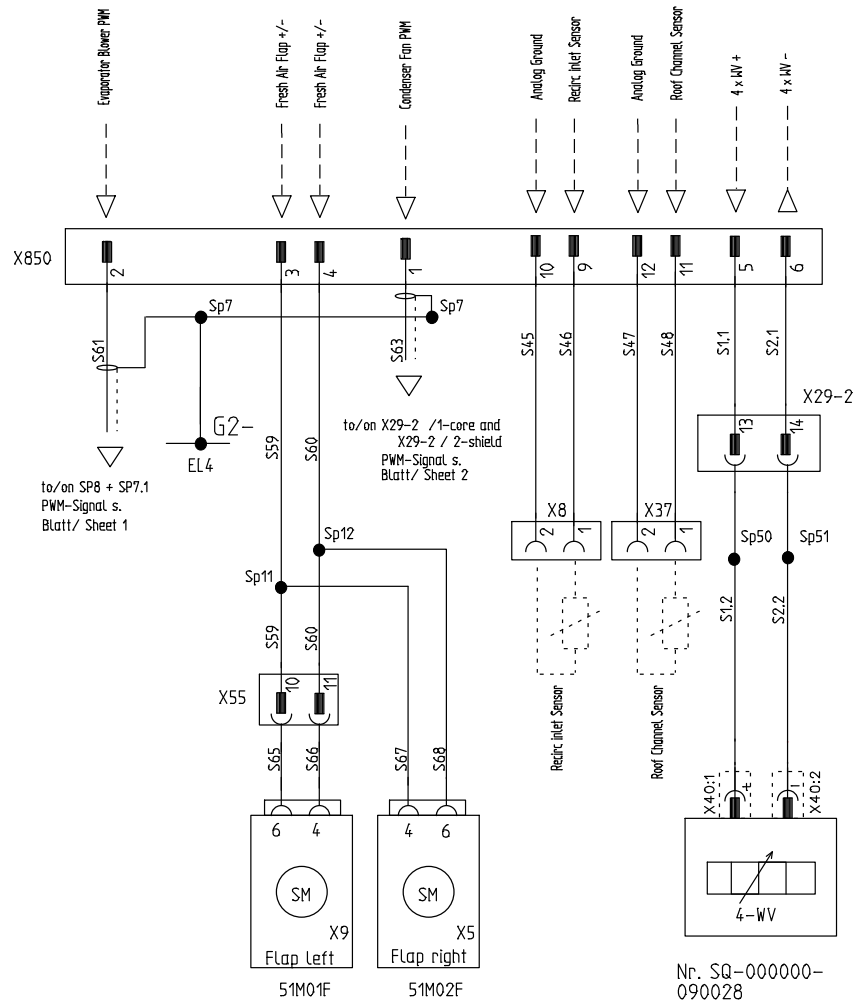
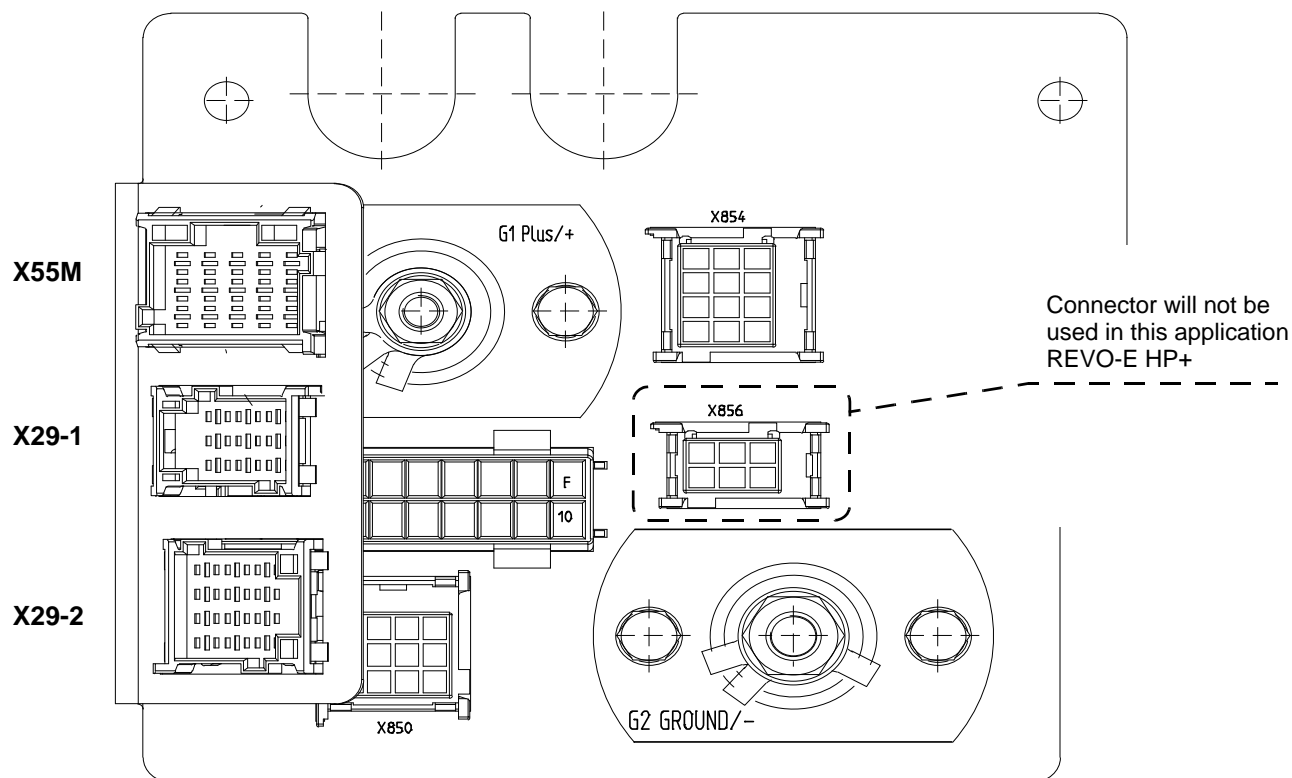

Fig. 602 Wiring diagram for REVO-E HP+ (Sheet 5)



Connector pin assignment		
Pin	X854	X850
1	Compressor Speed	Condenser Fan PWM
2	Electromagnetic valve (+)	Evaporator Blower PWM
3	LP/HP/No Error	Fresh Air Flap +/-
4	HVIL - detect 1 in	Fresh Air Flap +/-
5	HVIL detect 2 out	4WV+
6	Analog Ground Press Sensor	4WV-
7	Pressure Sensor Return	HP Sensor GND
8	Pressure Sensor Supply (+5V)	HP Sensor Return
9	Electromagnetic valve (+) for hot gas defrosting	Recirc inlet Sensor
10	NTC4	Analog Ground
11	F/I Enable	Roof Channel Sensor
12	Analog Ground	Analog Ground

Fig. 602 Wiring diagram for REVO-E HP+ (Sheet 6)

6.4 Frequency converter - electrical connections

6.4.1 600V DC power supply including HVIL connector

The air-conditioning system is linked to the HVIL monitoring system via the 600V DC wiring harness.

Inspect the operating voltage at the connections L1 (Pos1) and L3 (Pos2) with the designated voltage tester (CAT IV), see Fig. 603.

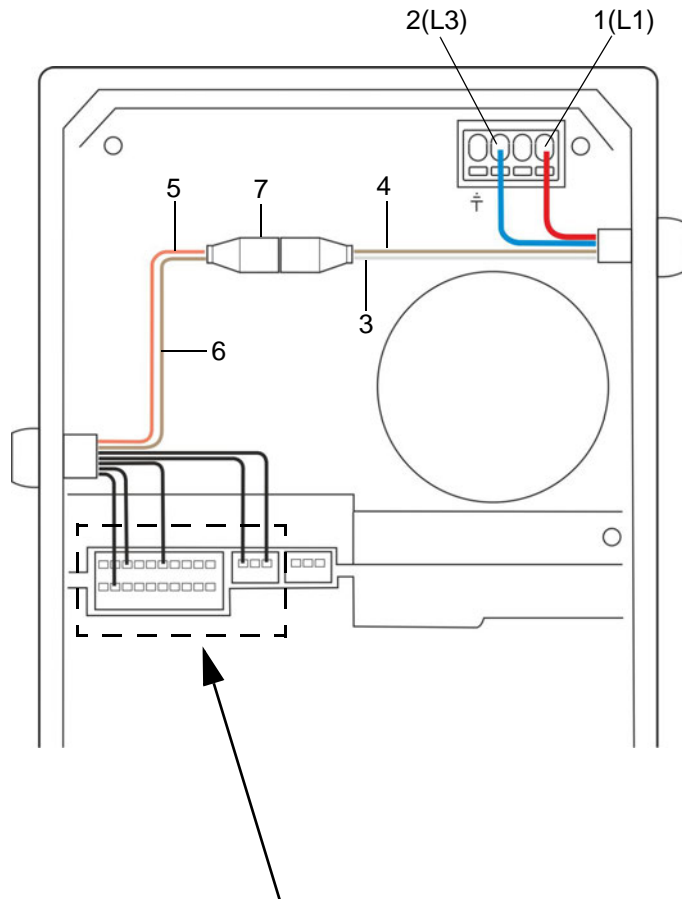

No.	Designation	Configuration	Cable color
1	L1	DC network (+)	Red
2	L3	DC network (-)	Blue
3	HVIL in vehicle	X61 Pin 1	White
4	HVIL out of vehicle	X61 Pin 2	Brown
5	HVIL in system	X61 Pin 1	Pink
6	HVIL out of system	X61 Pin 2	Brown

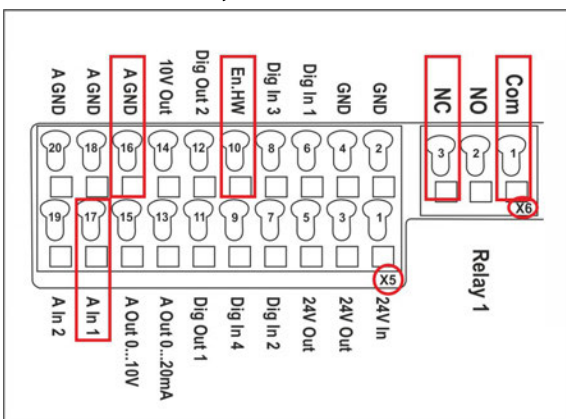

Application map

Strip	No.	Designation	Configuration	Cable color	Cable no.
X5	10	EN-HW	Approval	Yellow	4
	16	A GND (Ground 10V)	Ground	Gray	3
	17	A. In 1	Desired speed of compressor	Brown	6
X6	1	Com	Center contact of relay 1	Green	5
	3	NC	Break contact of relay 1	White	7

Cable assignment for application map

Fig. 603 Power supply 600V DC including HVIL connector



**6.4.2 400V AC voltage output**

The PE line as well as the lines to monitor the PTC sensor of the e-motor for the compressor are integrated into this cable in addition to the live wires.

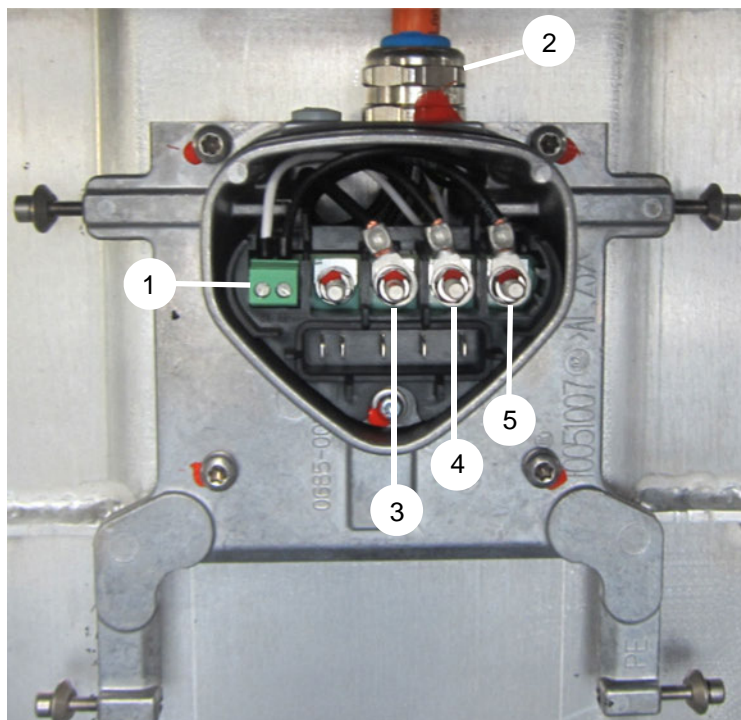

- 1 Connection for PTC sensor e-motor for compressor
- 2 Cable connection for 400V AC cable
- 3 U – connection
- 4 V – connection
- 5 W – connection
- 6 PE (within connection plate)

Phase designations on the individual cables must correspond to the designations on the compressor (cover graphic).

U ↔ U  
 V ↔ V  
 W ↔ W

Fig. 604 Voltage output 400V AC

**6.4.3 PE connection (potential equalizing)**

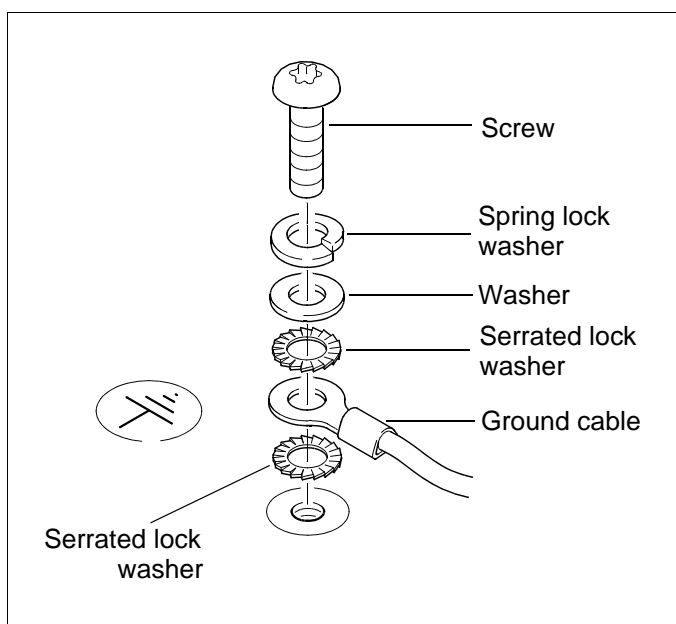

In order to guarantee a secure electrical connection when connecting the PE line, the order of the individual parts must be maintained (Fig. 605).

Fig. 605

6.5 Compressor - electrical connections

6.5.1 400V AC voltage supply

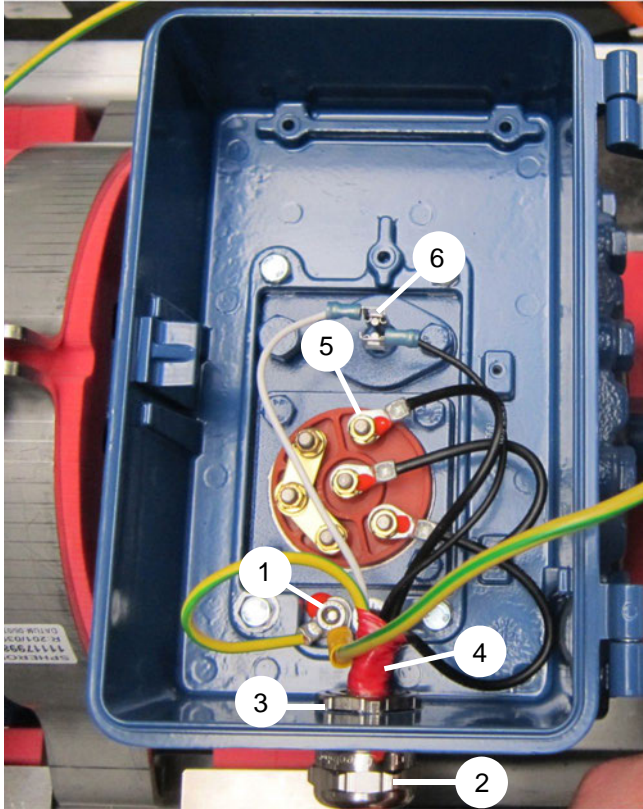

- 1 PE connection
- 2 Cable gland
- 3 Cable gland lock nut
- 4 Position marking cable
- 5 Phase connections for 400V AC (3)
- 6 Connection for PTC sensor for electrical motor

The position marking cable must be secured with lock nut during assembly.

Phase designations on the individual cables must correspond to the designations on the compressor (cover graphic).

U <-> U  
 V <-> V  
 W <-> W

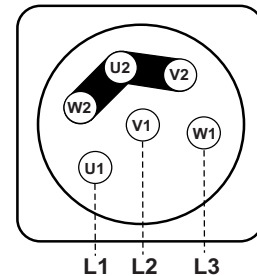

PE line is connected.  
 Cable for PTC sensor for e-motor is plugged in.

Fig. 606 Voltage supply 400V AC

6.5.2 PE connection (potential equalizing)

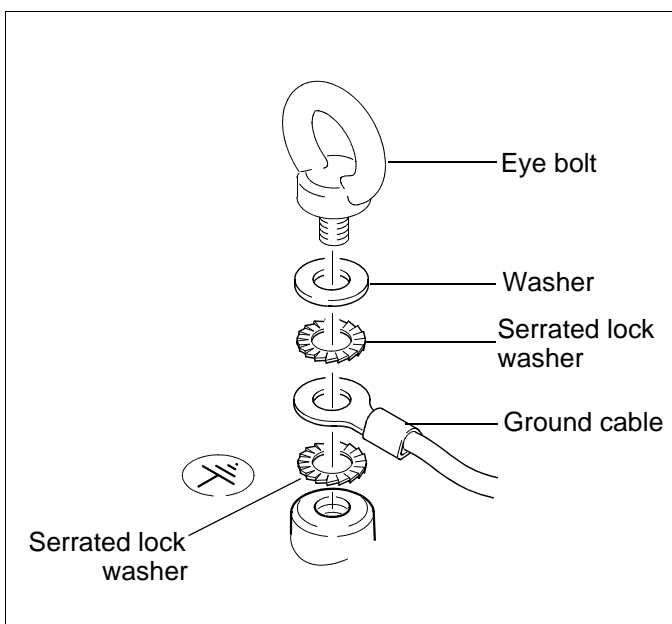

In order to guarantee a secure electrical connection when connecting the PE line, the order of the individual parts must be maintained (Fig. 607).

Fig. 607

## 7 Maintenance

### 7.1 Safety information



Follow the safety information and conditions from Chapter 1 (see 1.6).



The work described in the following requires proof of the following qualifications:  
See 1.6.1.

### 7.2 Versions of ADA

**NOTE:**

Most of the work described below is identical for HP and HP + systems. Wherever there are differences, this is explicitly stated. The information of some graphics apply for both versions. These graphics are marked as "exemplarily".

### 7.3 Maintenance and upkeep

Details can be found in the REVO-E maintenance and service plan (for the download link, see 1.5).

### 7.4 Inspection and maintenance

The rules in the evacuating and filling instructions for the REVO-E apply (for the download link, see 1.5).  
For work from this chapter where opening the refrigerant circuit is required, carry out the following preparation and follow-up work.

**Preparation work**

- Vehicle / air-conditioning system powered off (primary switch / battery disconnection switch)
- If necessary, remove protective cover for the compressor / frequency converter

- Open the side covers of the air-conditioning system and prop up with rods (attached to cover)
- Remove the coil of the solenoid valve and replace with permanent magnet
- Siphon refrigerant via high and low pressure connections on the compressor
- As soon as the system is open, always plug the openings with designated stoppers (prevents water absorption via refrigerator oil)

**Follow-up work**

- Exchange filter dryers
- Evacuation the air-conditioning system
- Check tightness

**ATTENTION:**

**The maximum pressure is 17 bar, the suction pressure sensor will become damaged otherwise!**

- Fill the air-conditioning system with R134a
- Remove the permanent magnet from the magnet valve and install the coil
- Mount / close the cover
- Test functionality
- Inspect oil level after 10 minutes of running system.

#### 7.4.1 Changing the fresh air filter

- Remove filter
- Clean filter area carefully
- Inspect heat exchanger for contamination / damages
- Insert filter

**ATTENTION!**

**Note the position / direction of air flow exactly. Arrow marks on the upper edge of the filter in the direction of the heat exchanger.**

#### 7.4.2 Changing the filter dryer

The replacement intervals for the filter dryer are found in the maintenance and service plan.  
For removal and insertion, see Chapter 9.5.

**7.4.3 Inspecting the oil level of the compressor**

Inspect the oil level after at least 10 minutes of running the system.

Inspect the oil level by opening the rear side of the compressor pan (Fig. 701).

The correct oil level is between the minimum and maximum display Fig. 701. For deviations, see Chapter 7.4.4.

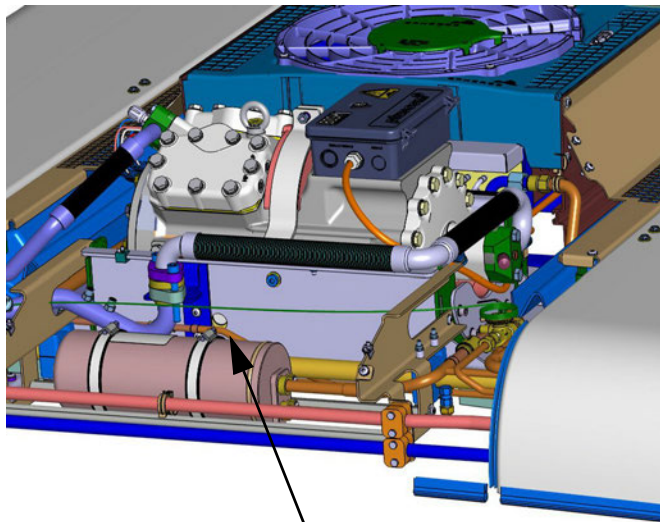

Opening for sight glass

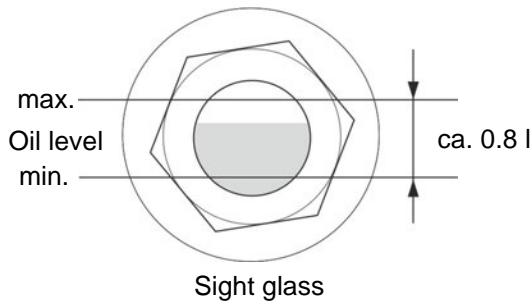

Fig. 701 (exemplarily)

**7.4.4 Changing the compressor oil**

**NOTE:**

For this procedure, follow the preparation and follow-up work described in 7.4.

Always change the compressor oil when conducting servicing or repair work on the compressor.

Open the oil filling screw (Fig. 702), siphon out the old oil and feed in the new oil.

The amount of oil to put in corresponds to the amount taken out. The oil level, however, must be verified using the sight glass after running the system for 10 min.

The following refrigerator oils are approved for use in the compressor:

- Fuchs Reniso Triton SE55
- Fuchs SEZ 32
- ICI Emkarate RL 46 S
- Mobil Arctic AL46
- Shell Clavus R 46

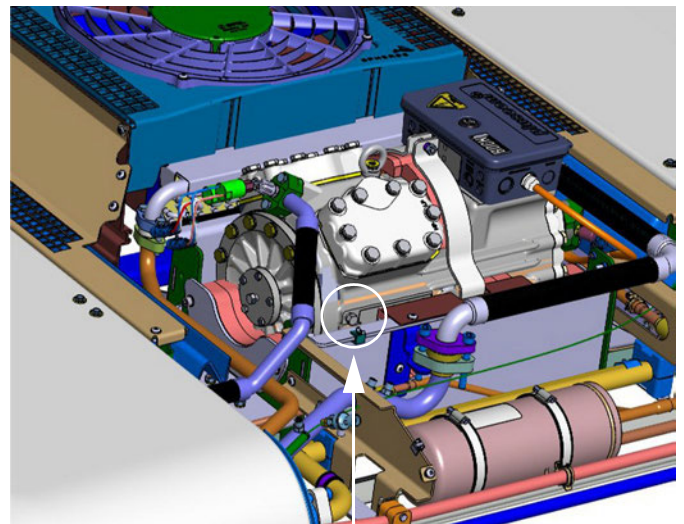

Filling screw  
Compressor oil

Fig. 702 (exemplarily)



## 8 Removal and installation of components (high-voltage system)

### 8.1 Safety information



Follow the safety information and conditions from Chapter 1 (see 1.6).

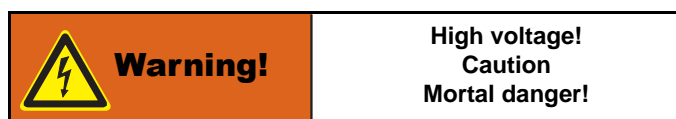

The work described in the following requires proof of the following qualifications:

See 1.6.1.

It is strictly forbidden to work on high-voltage components that are under voltage! **MORTAL DANGER !!**

### 8.2 Versions of ADA

**NOTE:**

Most of the work described below is identical for HP and HP + systems. Wherever there are differences, this is explicitly stated. The information of some graphics apply for both versions. These graphics are marked as "exemplarily".

### 8.3 Preparation/follow-up

The use of a suitable and secure lifting device is required when lifting heavy components.



Use only suitable and technically secure lifting devices (>100kg).

Do not stand under suspended loads!

#### 8.3.1 High-voltage system

The vehicle's battery system must be separated by an authorized (by the vehicle manufacturer) and trained specialist of high-voltage systems (decommissioning). The rules provided by the vehicle manufacturer must be followed precisely.

Before beginning any work on the high-voltage system, always make sure there is no voltage present at the power supply of the frequency converter, using a voltage tester (CAT IV) suitable for HV systems (Fig. 603 Chap. 6.4)!

#### 8.3.2 Refrigeration section

When working on the refrigerant circuit, the rules for evacuating and filling the REVO-E apply. Replace the sealing rings from the opened connections and oil them before replacing (refrigerator oil). If opening the refrigerant circuit is required, the following preparation and follow-up work must be completed.

**Preparation work**

- Vehicle / air-conditioning system powered off (primary switch / battery disconnection switch)
- If necessary, remove protective cover for the compressor / frequency converter
- Open the side covers of the air-conditioning system and prop up with rods (attached to cover)
- Remove the coil of the solenoid valve and replace with permanent magnet
- Siphon refrigerant via high and low pressure connections on the compressor
- Close openings of components of the refrigerant circuit with suitable plugs (prevents water absorption by the refrigerant oil)

**Follow-up work**

- Exchange filter dryers
- Evacuation the air-conditioning system
- Check tightness

**ATTENTION:**

**The maximum pressure is 17 bar, the suction pressure sensor will become damaged otherwise!**

- Fill the air-conditioning system with R134a
- Remove the permanent magnet from the magnet valve and install the coil
- Mount / close the cover
- Test functionality

Torque table, see [Attachment A](#).

## 8.4 Frequency converter removal/ installation

### 8.4.1 Remove the frequency converter

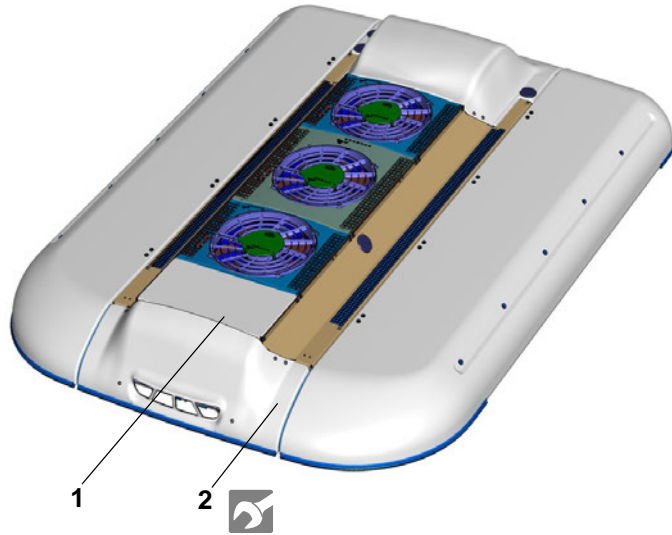

- 1 Cover of the frequency converter
- 2 Torx screws (6)

Fig. 801

1. Prepare to remove the frequency converter
  - Loosen the mount for the grounding cable (4).
  - Loosen the diagnostic cable (3).
  - Loosen the with sealing wax secured captive cover screws (1).
  - Lift the cover, remove the grounding cable.
2. Disconnect the electrical connections of the frequency converter.
  - Check the connections L1 and L3 (Fig. 603) are voltage free using a suitable voltage tester (CAT IV).
  - Remove power supply from the terminal strip.
  - Remove the HVIL plug.

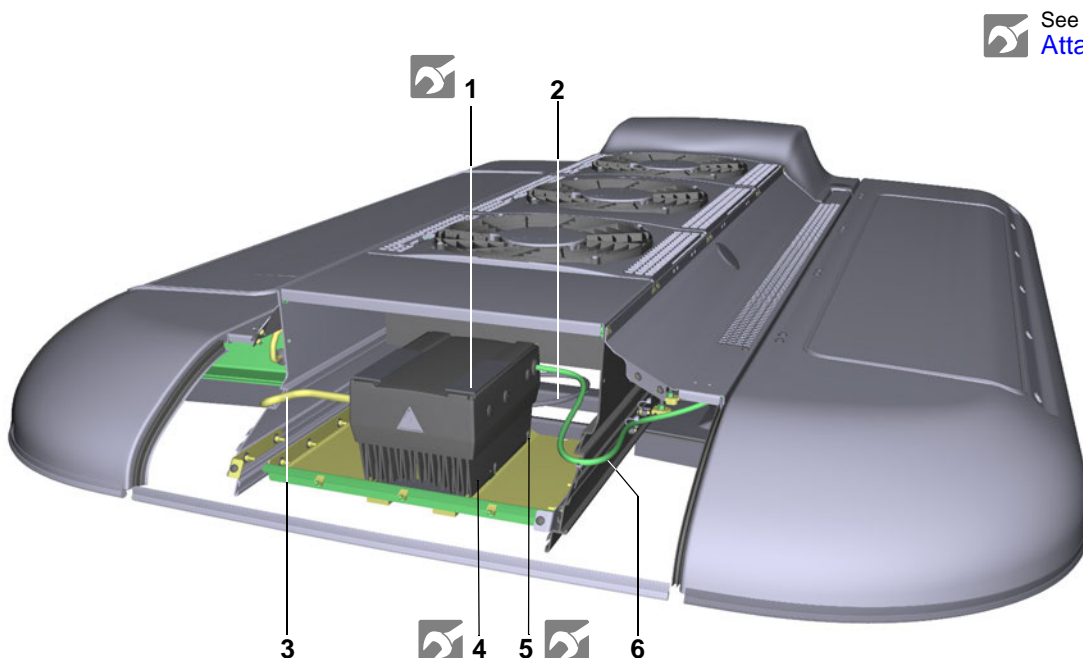

 See torque table  
[Attachment A](#)

- |   |                                   |
|---|-----------------------------------|
| 1 Frequency converter Cover screws (4x) | 4 Mount for grounding cable       |
| 2 400V AC cable                         | 5 Screws (4x) with centering cone |
| 3 Diagnostic cable                      | 6 600V DC cable for power supply  |

Fig. 802

- Remove cable screw for 600V DC cable (tension relief), remove from housing.
- Remove control lines from terminal strip of the application board (Fig. 603).
- Remove cable screw for signal cable (tension relief), remove from housing.
- Disconnect grounding cable from housing of frequency converter.
- Loosen cone screw Fig. 802, Pos 5.
- Disassemble the frequency converter.
- Pull the frequency converter firmly up and off the mounting plate (Fig. 803).

### 8.3.2 Install the frequency converter

- Ensure that connection terminals U / V / W (Fig. 604) of the 400V AC cable for the mounting plate are securely fastened.
- Set the frequency converter on the mounting plate (Fig. 803), the collar of the plate will dip into opening in the bottom of the heat sink of the frequency

- converter.
- Inspect the positioning of the centering cone of the fastening screws.
- Attach the frequency converter.
- Pull the control line cable into the housing and attach cable gland.
- Connect control lines according to wiring diagram Fig. 603 (chapter 6).
- Pull the 600V DC cable of the power supply into the housing and attach cable gland.
- Connect power supply according to wiring diagram Fig. 603 (chapter 6).
- Connect the HVIL plugs.
- Inspect the internal grounding cable to see if there is contact with the cover.
- Install the cover using screws and secure it against unauthorized access using sealing wax.
- Connect grounding cable according to Fig. 604.
- Connect diagnostic cable and tighten by hand.
- Install protective cover.
- Test functionality (using diagnostic as needed).

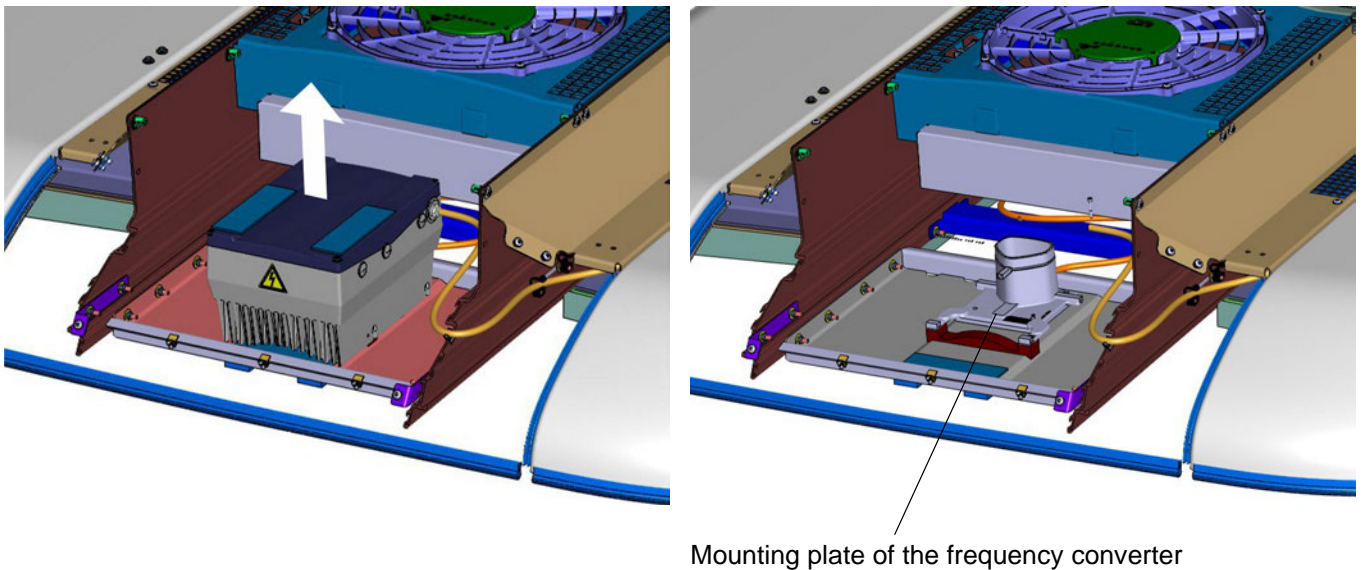

Fig. 803 (exemplarily)



## 8.4 Refrigerant compressor removal/ installation

### 8.4.1 Remove the compressor

1. Preparation work, see 8.3.

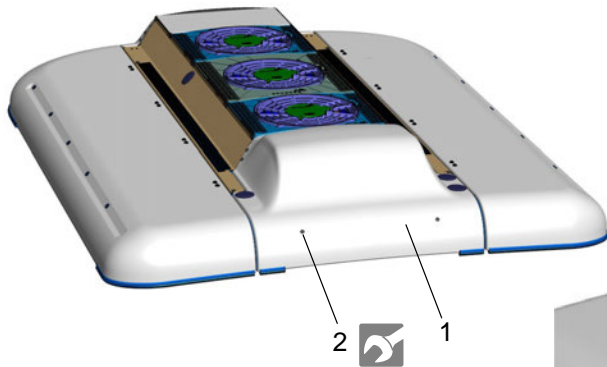

See torque table  
Attachment A

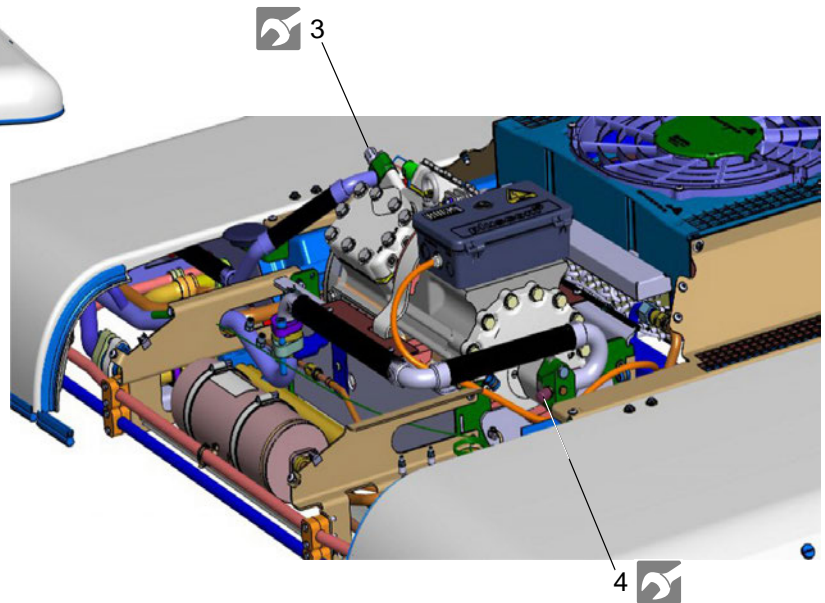

- 1 Protective cover of compressor
- 2 Torx screws (6)
- 3 High-pressure / fluid connection
- 4 Low-pressure / suction connection

Fig. 804 (exemplarily)

2. Disconnecting the electrical lines
  - Open the terminal box of the compressor using the special key (attached to the compressor).
  - Loosen electrical connections, see Fig. 606.
  - Loosen lock nuts (3, Fig. 606) of the cable glands for the 400V AC cable and pull the cable out of the terminal box.

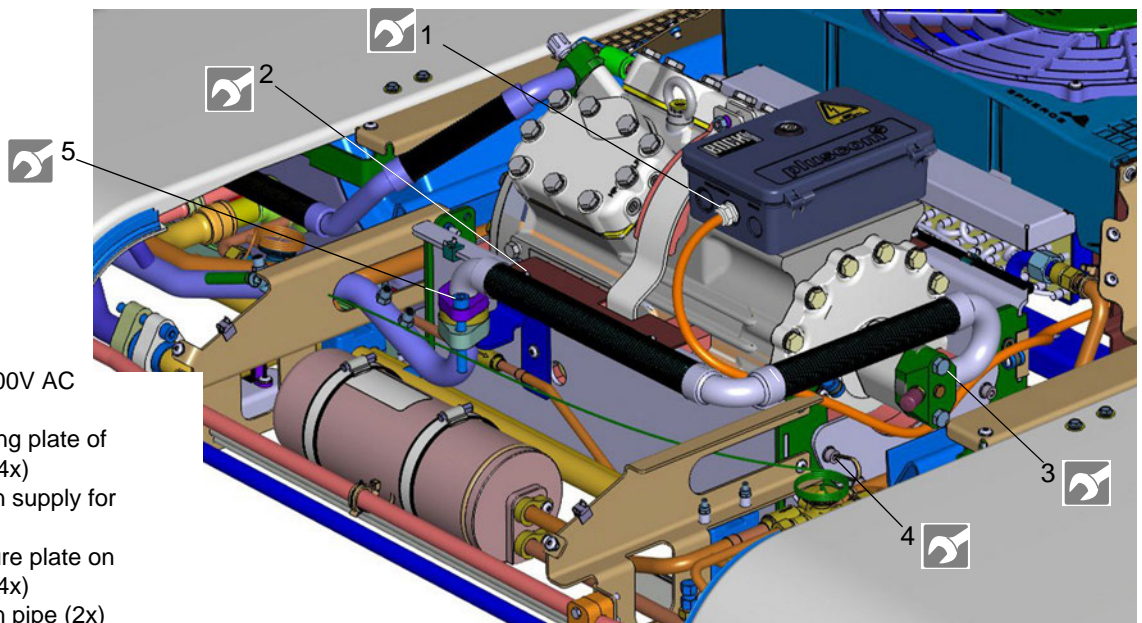

See torque table  
Attachment A

- 1 Cable gland for 400V AC cable
- 2 Screws for retaining plate of compressor pan (4x)
- 3 Screws for suction supply for compressor (2x)
- 4 Screws for pressure plate on compressor pan (4x)
- 5 Screws for suction pipe (2x)

Fig. 805 (exemplarily)

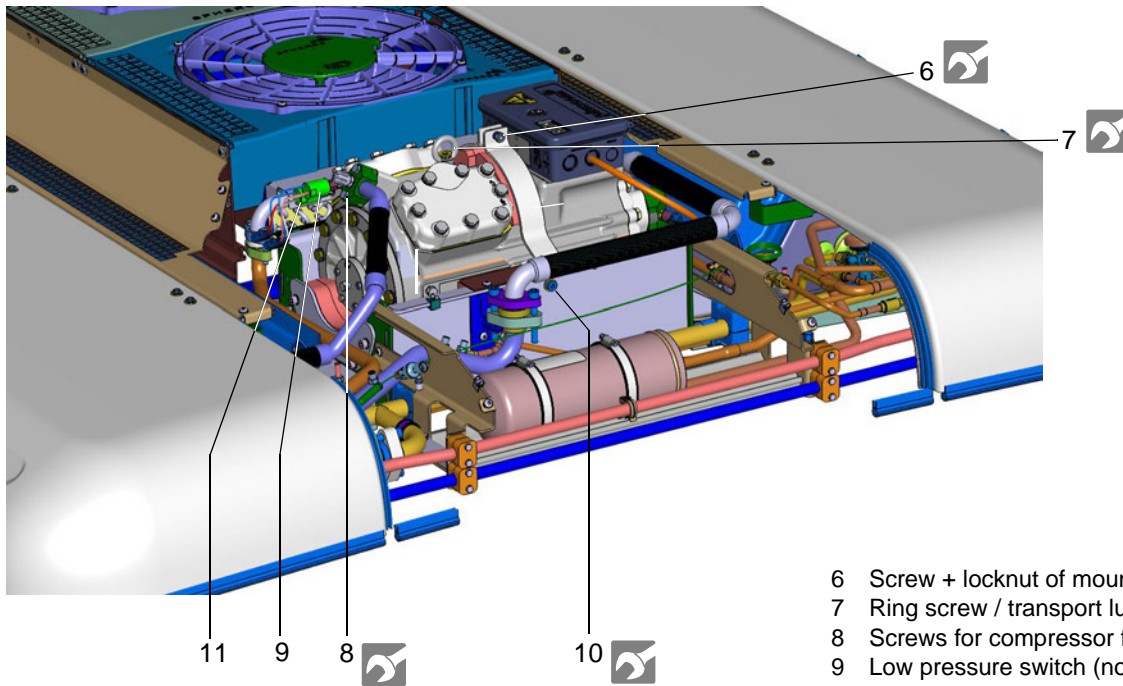

See torque table  
Attachment A

- 6 Screw + locknut of mounting bracket
- 7 Ring screw / transport lug / grounding
- 8 Screws for compressor fluid lines
- 9 Low pressure switch (not at 11123865\_)
- 10 Screws for mounting bracket of compressor (both sides)
- 11 High pressure switch

Fig. 806

3. Remove attachments / connections
  - Remove 24V cables from compressor pan (not pictured).
  - Remove screws (2) that attach the retaining clamp to the compressor pan and remove retaining clamp.
  - Suction line (see 9.13).
  - Remove screws (4) that hold the pressure plate on the compressor and remove pressure plates.
  - Fluid line (see 9.13).
  - Low / high pressure switch (see 9.12).
  - Remove screws (6 and 10) that hold the mounting bracket and remove mounting bracket.
  - Separate grounding cable by pulling out ring screws (7) from compressor housing, screw ring screws back in.
  
4. Removing compressor
  - Lift compressor at the ring screw (7) from compressor pan with suitable lifting device.

**NOTE:**

Ensure components of the compressor mounting do not fall.

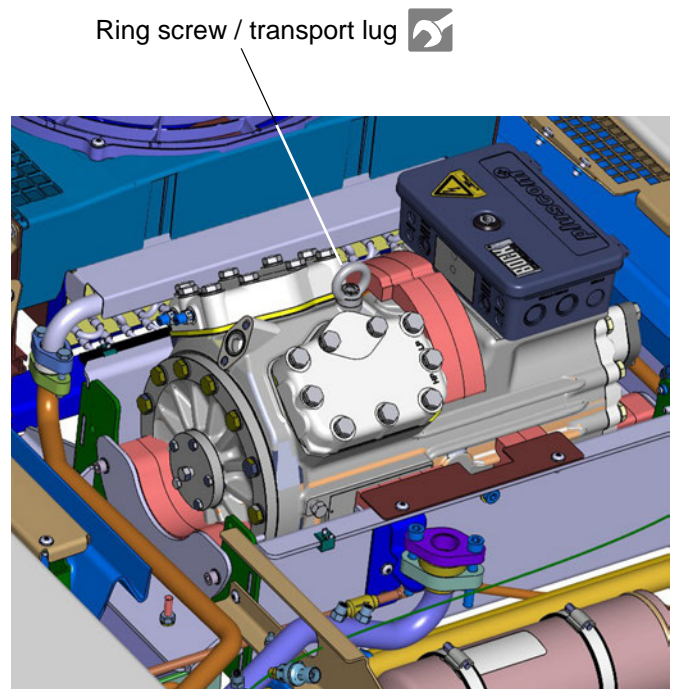

Fig. 807



### 8.4.2 Comparing the old/new oil level

While the air-conditioning system is being operated, some of the compressor oil will spread in the refrigerant circuit. The replacement compressor is already filled with 1.3 l of compressor oil. Before replacement, compare the oil levels of both refrigerant compressors via the sight glass and adjust the replacement compressor as needed in order to avoid overfilling the air-conditioning system (see 7.4.4). Note the minimum and maximum oil level.

Check, and adjust as needed, the oil level of the air-conditioning system after commissioning.

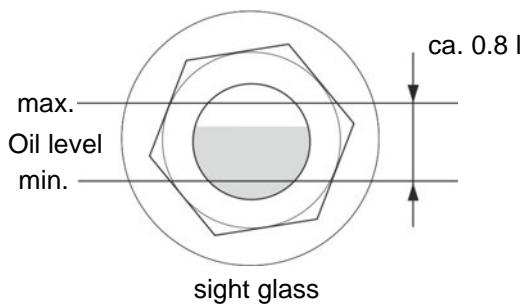
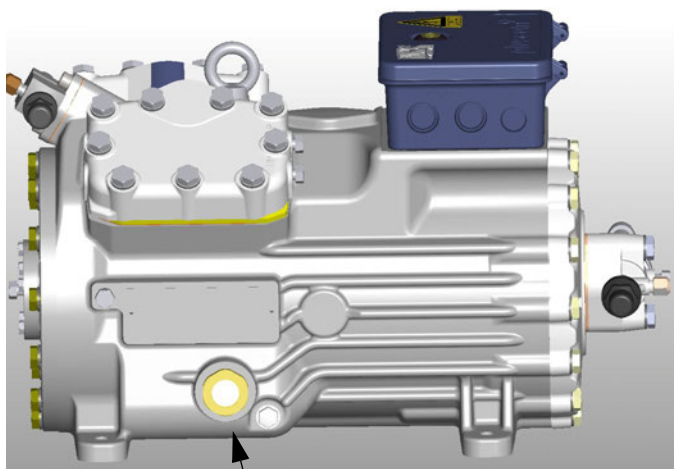
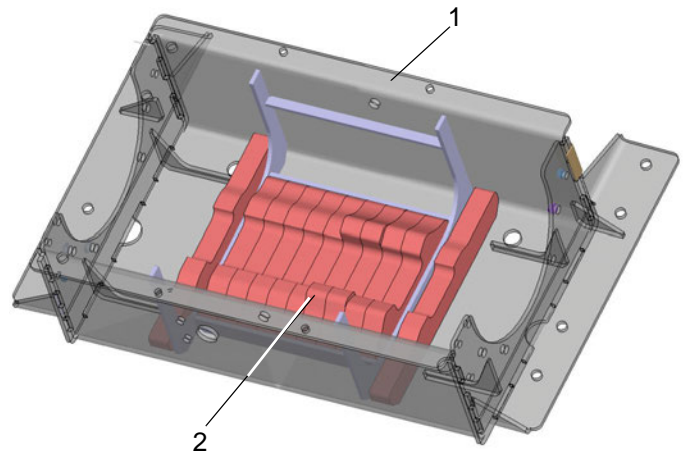

Fig. 808

### 8.4.3 Install the compressor

1. Set into the compressor pan
  - Inspect the positioning of the foam in the compressor pan (Fig. 809).
2. Insert and attach the compressor.



- 1 Compressor pan
- 2 Absorption foam of compressor

Fig. 809

- Lift the compressor on the ring screw with suitable lifting device and place into compressor pan with side foam (3, Fig. 810).

**NOTE:**

The sight glass oil level must be well visible when opening the compressor pan.

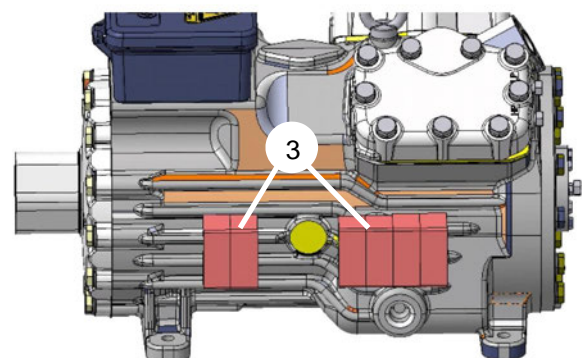
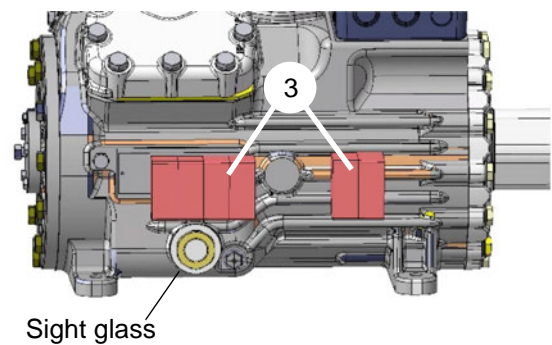

Fig. 810

- Insert foam (4, Fig. 811) on both long sides in the compressor pan and affix with compressor pressure plate.

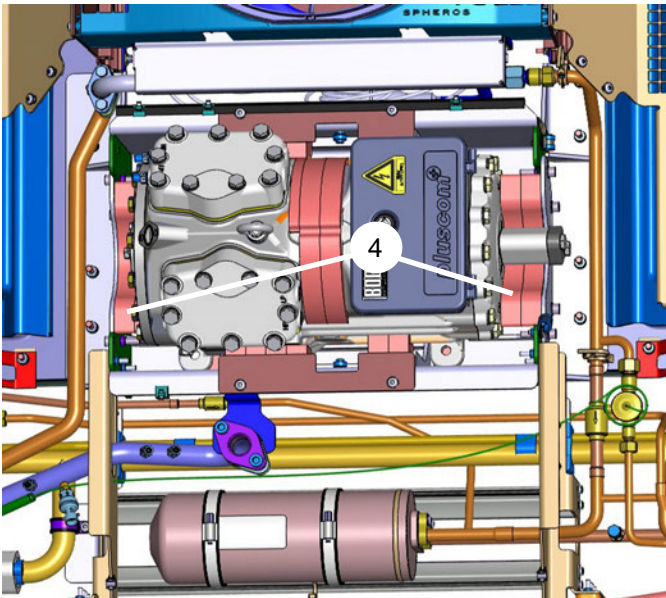

Fig. 811

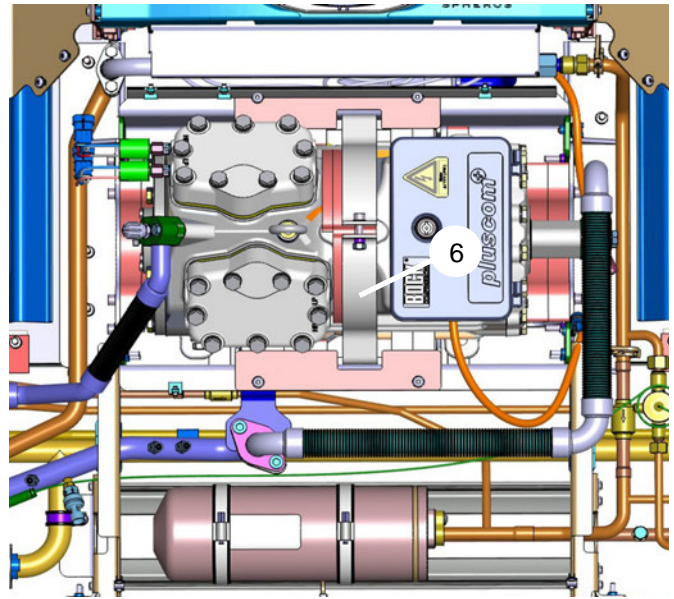

Fig. 813

- Align foam (5, Fig. 812) on the upper side of the compressor and reattach compressor with mounting bracket (6, Fig. 813). Secure screw with sealing wax against unauthorized access.

**NOTE:**

Please always comply with given torque. Otherwise, the foam will lose its absorbent affect. This causes the transference of vibration to the bus roof.

- Install mounting parts of the compressor in the opposite order (Removing compressor, point 3.). Use new seals when removing the refrigerant cables.
- Lead the 400V AC cable through the opening in the terminal box of the compressor.
- Connect the compressor to the electrical system (see 6.5).
- Close the cap of the terminal box with the key. Reattach the key to the compressor.

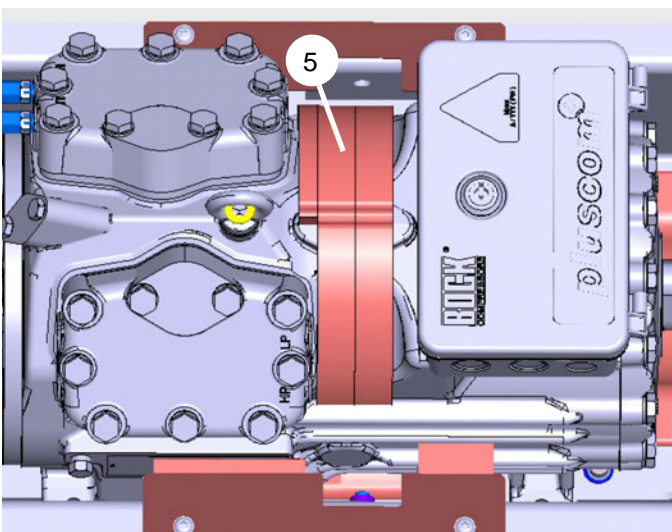

Fig. 812

### 8.5 600V DC/ 400V AC high-voltage cable removal/ installation

 <b>Warning!</b>	<p style="text-align: center;">High voltage! Caution Mortal danger!</p>
---	---

Follow the safety information in 1.6.

#### 8.5.1 Remove the 600V AC cable

The cable's path is described in 3.3, Fig. 3.

**NOTE:**

Do not replace individual components, for reasons of safety.

1. Preparation
  - Remove protective cover of the frequency converter, open right side cover of the air-conditioning system and prop open with bar (attached to cover).

 <b>Warning!</b>	<p style="text-align: center;">High voltage! Caution Mortal danger!</p>
---	---

- **Conduct work in accordance with 8.3.1 (high-voltage system).**
2. Removal
    - Separate vehicle connections to the REVO-E in the vehicle's interior.
    - Uncover and disconnect the 600V DC cable on the frequency converter (8.4.1 point 2.).
    - Dismount connector of plug from pan by loosening the lock nut on the lower side of the REVO-E (Fig. 814).
    - Loosen cable clamps in the compressor pan and pull out 600V DC cable.

#### 8.5.2 Install the 600V DC cable

- Install cable in the opposite order. Connecting the clamps, see 6.4.

**ATTENTION:**

**The cable must not touch any sharp edges - abrasion hazard!**

#### 8.5.3 Remove the 400V AC cable

The cable's path is described in 3.3, Fig. 3.

**NOTE:**

The 400V AC cable is only preinstalled as a replacement part on the mounting plate of the frequency converter. Do not replace individual components.

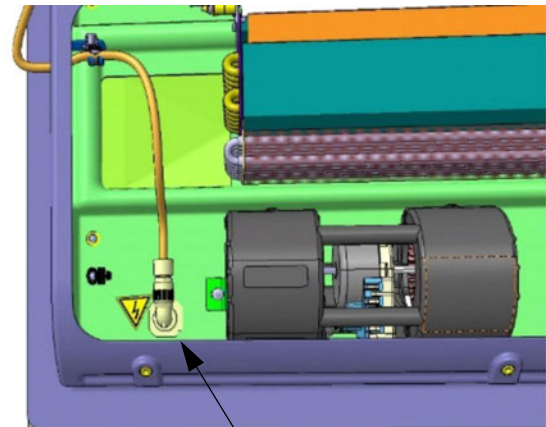

600V DC plug connector in the air-conditioning system pan: View from above

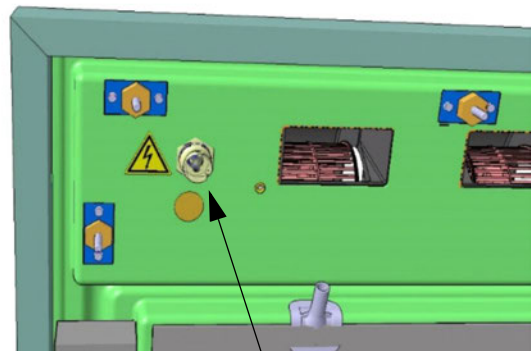

View from below (cable unplugged)

Fig. 814 (exemplarily)

1. Preparation
  - Removing the compressor (see 9.4).

 <b>Warning!</b>	<p style="text-align: center;">High voltage! Caution Mortal danger!</p>
---	---

- **Conduct work in accordance with 8.3.1 (high-voltage system).**

2. Removal
  - Disconnect the 400V AC cable from the compressor(see 8.4.1, point 2.).
  - Remove cable clamps (Fig. 815) on the compressor pan.
  - Removing the frequency converter (see 8.3.2).
  - Remove the screws of the frequency converter mounting plate.
  - Loosen the attachments of the 400V AC cable to the crossbars and remove the cable.



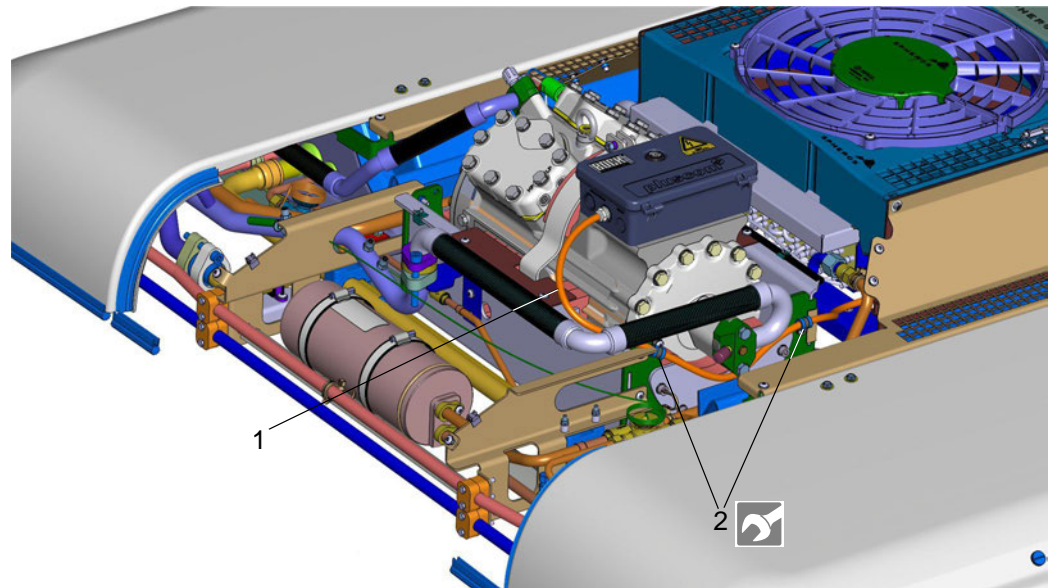

See torque table  
Attachment A

- 1 400V AC cable
- 2 Clamps for 400V AC cable

Fig. 815 (exemplarily)

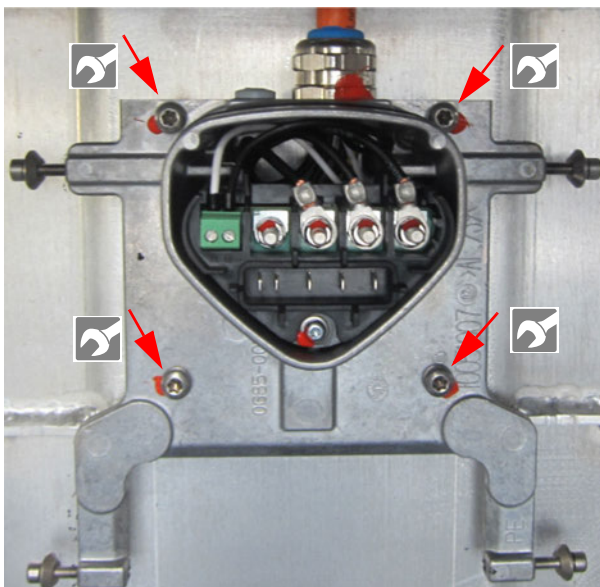

Fig. 816 Screws of the mounting plate

#### 8.5.4 Install the 400V AC cable

- Replace the plug-in holder for the 400V AC cable to the crossbars (Fig. 817).
- Screw on the mounting plate of the frequency converter (Fig. 816).
- Lay the 400V AC cable according to Fig. 815 and Fig. 817 and attach to the traverses and compressor pan.

#### ATTENTION:

The cable cannot touch any sharp edges - abrasion hazard!

- Connect the 400V AC cable to the compressor (see 6.5).
- Install the condenser (see 9.4).

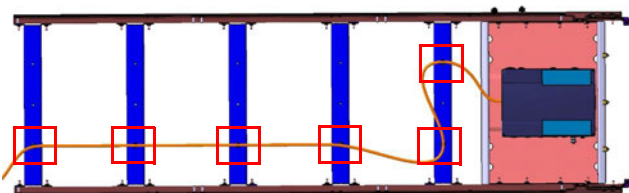

Fig. 817 Moving the 400V AC cable with fixing points

## 9 Removal and installation of components

### 9.1 Safety information



Follow the safety information and conditions from Chapter 1 (see 1.6 ).



The work described in the following requires proof of the following qualifications:  
See 1.6.1 under working on the refrigeration section of the air-conditioning system.

### 9.2 Versions of ADA

**NOTE:**

Most of the work described below is identical for HP and HP + systems. Wherever there are differences, this is explicitly stated. The information of some graphics apply for both versions. These graphics are marked as "exemplarily".

### 9.3 Preparation/follow-up

When working on the refrigerant circuit, the rules for evacuating and filling the REVO-E apply. Replace the sealing rings from the opened connections and oil them before replacing (refrigerator oil). If opening the conditioning circuit is required, the following preparation and follow-up work is required.

**Preparation work**

- Vehicle / air-conditioning system powered off (primary switch / battery disconnection switch)
- If necessary, remove protective cover for the compressor / frequency converter
- Open the side covers of the air-conditioning system and prop up with rods (attached to cover)
- Remove the coil of the solenoid valve and replace with permanent magnet
- Siphon refrigerant via high and low pressure connections on the compressor
- Close openings of components of the refrigerant circuit with suitable plugs (prevents water absorption by the refrigerant oil)

**Follow-up work**

- Exchange filter dryers
- Evacuation the air-conditioning system
- Check tightness

**ATTENTION:**

The maximum pressure is 17 bar, the suction pressure sensor will become damaged otherwise!

- Fill the air-conditioning system with R134a
- Remove the permanent magnet from the magnet valve and install the coil
- Mount / close the cover
- Test functionality / SCT components test

Torque table, see [Attachment A](#).

### 9.4 Condenser module removal/ installation

#### 9.4.1 Removal of the condenser module

Observe the safety instructions in Cha. 8!

1. Preparation

**NOTE:**

The condenser module as spare part is only available as pre-assembled unit. Replacement of individual parts is not possible. Minimum of 2 persons is required.

- Do the preparation work according to 9.3.
2. Removal ([Fig. 901](#))
- Protective grille (3)
  - Refrigerant line collector - condenser (7)
  - Pressure line compressor (5)
  - Refrigerant line condenser - dryer (6)
  - Disconnect electrical connections X29-2 condenser wiring harness at terminal board (see [Abb. 601, Blatt 6](#)).
  - Remove wiring harness from clips.
  - Remove the 24V wiring harness of the frequency converter (see Cha. 8.4.1, step 1/2).
  - Remove screws (4) securing the condenser module.
  - Lift out the condenser module by two persons.
  - Close the openings of the refrigerant circuit and the condenser module.
  - Remove the axial fan (see [9.7.3](#)).
  - Remove the wiring harness from the condenser module.

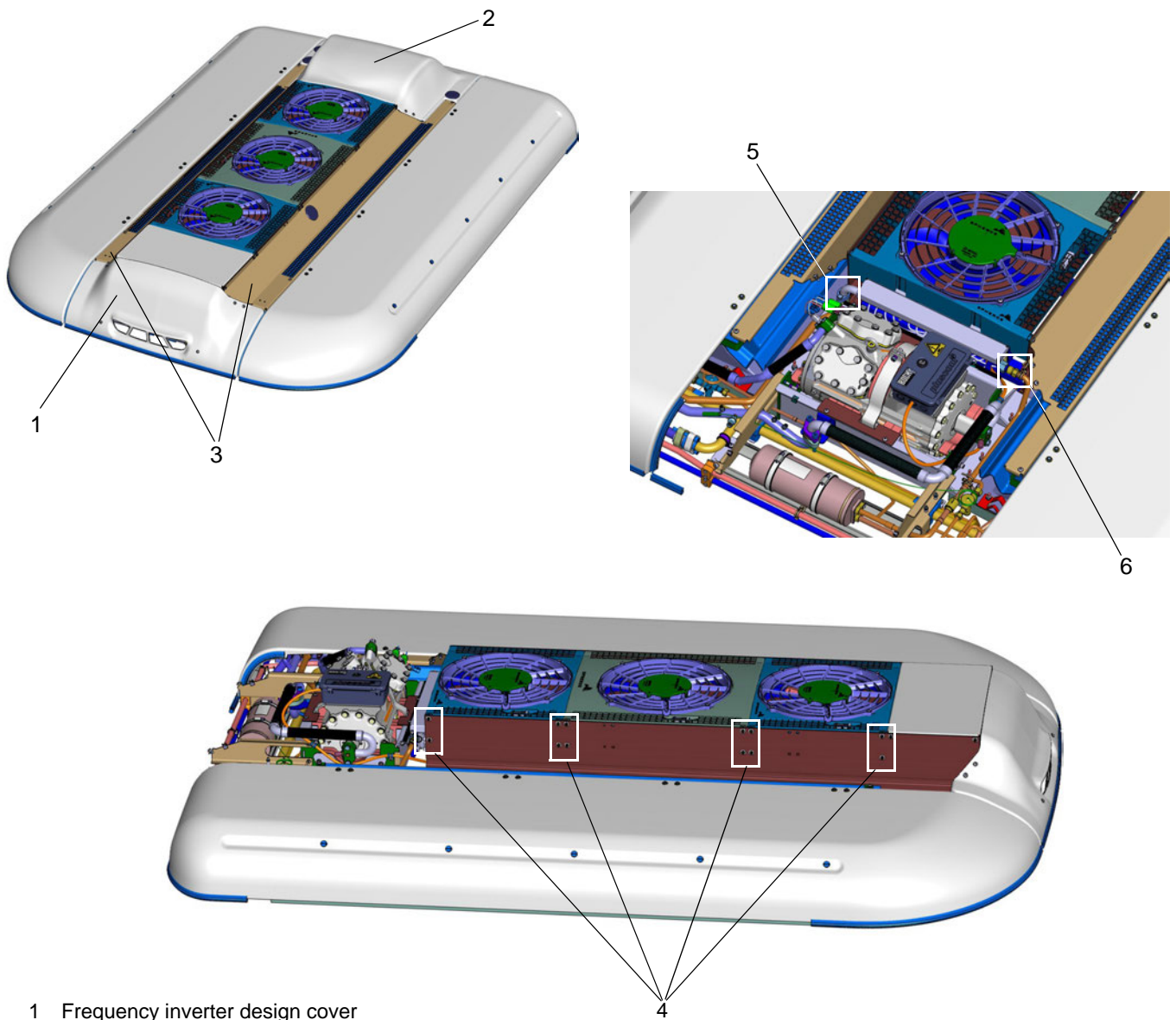

- 1 Frequency inverter design cover
- 2 Compressor design cover
- 3 Protective grille
- 4 Attachment condenser module
- 5 Pipe pipe group 4-way reversing valve - outer heat exchanger
- 6 Pipe collector - outer heat exchanger

Fig. 901 (exemplarily)

### 9.3.2 Installation of the condenser module

- The installation of the condenser module is carried out in reverse order. Thereby the gaskets of the refrigerant circuit are to be replaced!
- Do the final work according to 9.3.



9.4 Expansion valves removal/ installation

9.4.1 Positions of the expansion valves and the associated contact sensors

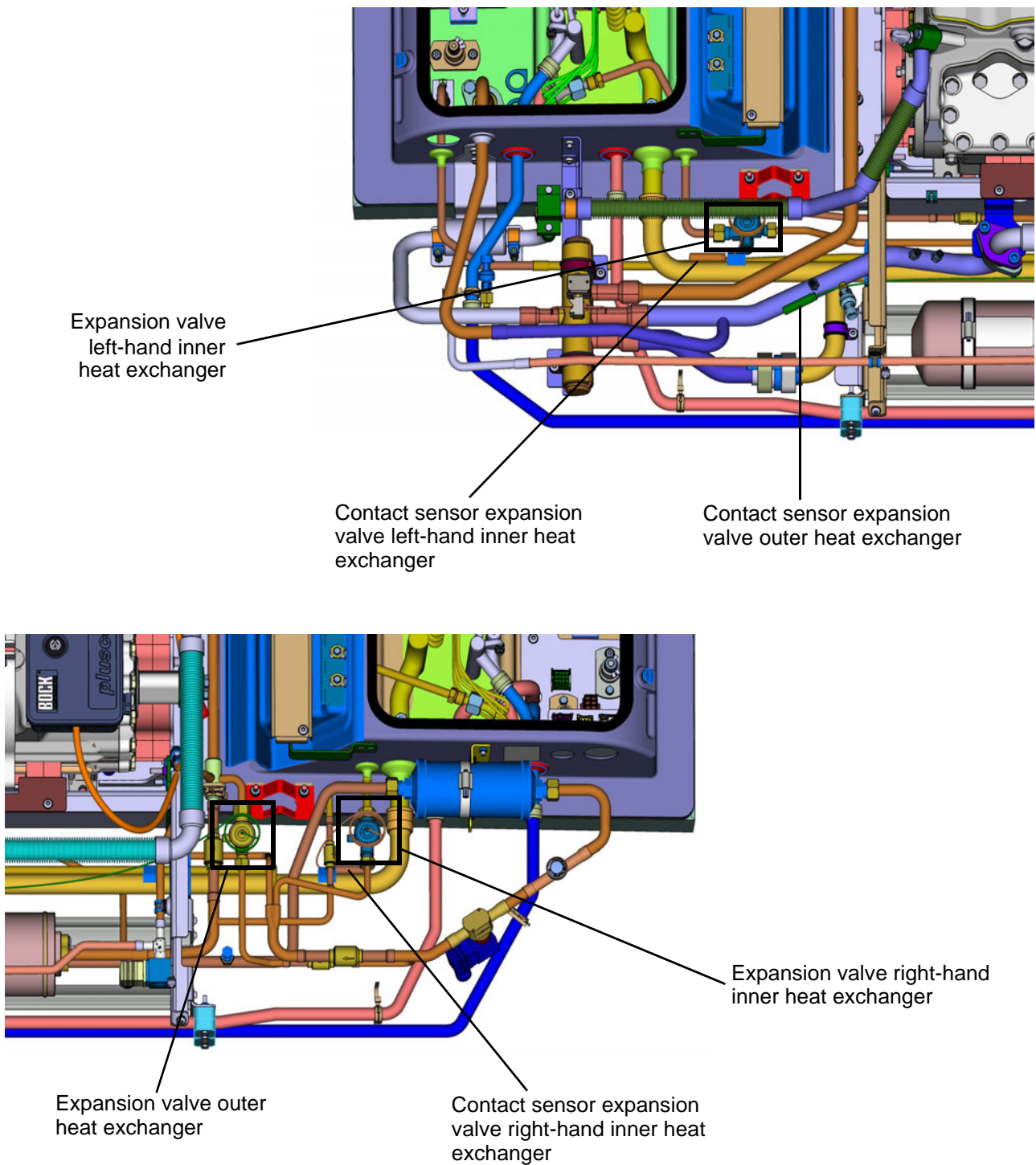
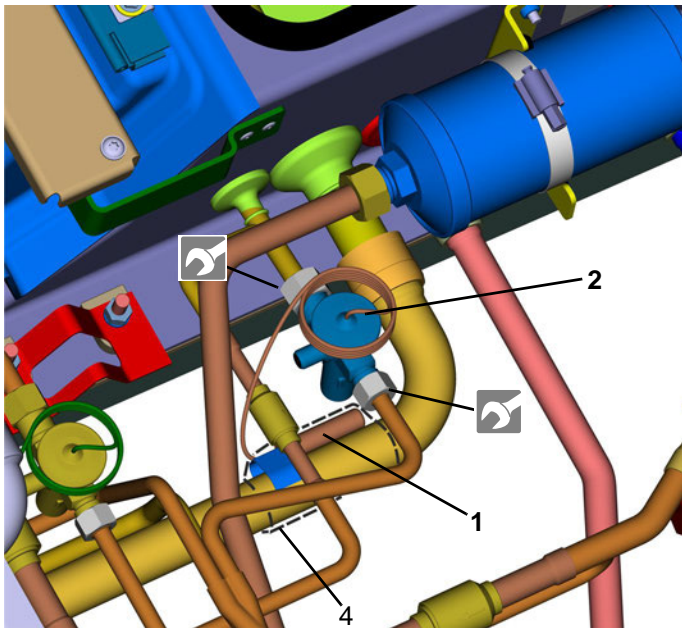

Fig. 902 Positions of expansion valves and the associated contact sensors

### 9.4.2 Remove an expansion valve

- Conduct preparation work according to 9.3.
- Remove tar binding (4) and holding clamp (3) from thermostat sensor (1).
- Remove cap nuts from the expansion valve (2) and remove expansion valve.



### 9.4.3 Install an expansion valve

- Apply refrigerator oil to sealing rings.
- Place the expansion valve (2) into the location of installation and attach with cap nuts.
- Attach thermostat sensor (1) with holding clamp (3, Fig. 903) and wrap with tar binding (4).
- Conduct follow-up work according to 9.3.

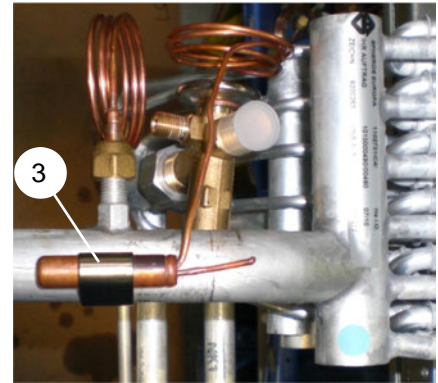

Fig. exemplarily

See torque table  
Attachment A

- 1 Thermostat sensor with safety clamp
- 2 Expansion valve
- 3 Holding clamp for thermostat sensor
- 4 Tar binding (dashed)

Fig. 903

9.5 Filter dryer removal/ installation

9.5.1 Remove the filter dryer

- Conduct preparation work according to 9.3.
- Loosen cap nuts on filter dryer. While doing so, prevent dryer filter from twisting with suitable tool.
- Loosen retaining clamp.
- Remove filter dryer.

9.5.2 Install the filter dryer

**ATTENTION:**

The arrow mark on the filter dryer (Fig. 904) must be in the flow through direction of the refrigerant (right)!

- Apply refrigerator oil to sealing rings.
- Place the filter dryer into the location of installation and attach with cap nuts. While doing so, prevent dryer filter from twisting with suitable tool.

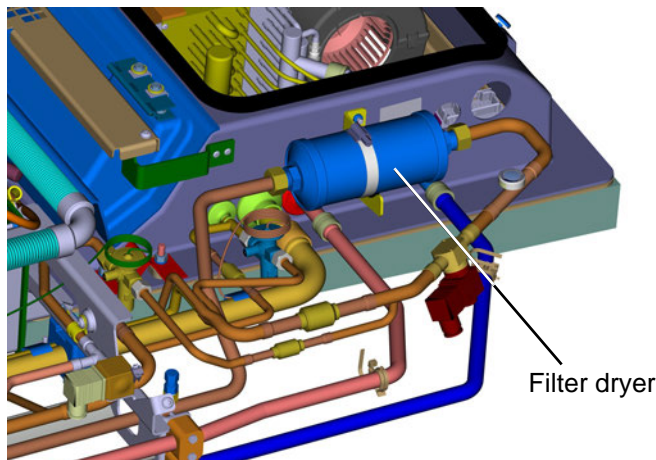

Fig. 904

- Attach retaining clamp.
- Conduct follow-up work according to 9.3.

9.6 Receiver removal/ installation

9.6.1 Remove the receiver

- Conduct preparation work according to 9.3.
- Loosen SMA connection (3, Fig. 905) of the refrigerant tube.
- Loosen retaining clamp (2).
- Remove receiver (1).

9.6.2 Install the receiver

- Replace the o-rings of the line connectors and apply refrigerator oil
- Place the new receiver into location of installation and orient around the position of the SMA connections.
- Attach SMA connections (3).
- Attach retaining clamp (2).

See torque table  
Attachment A

- 1 Receiver
- 2 Retaining clamps
- 3 SMA connection refrigerant tubes

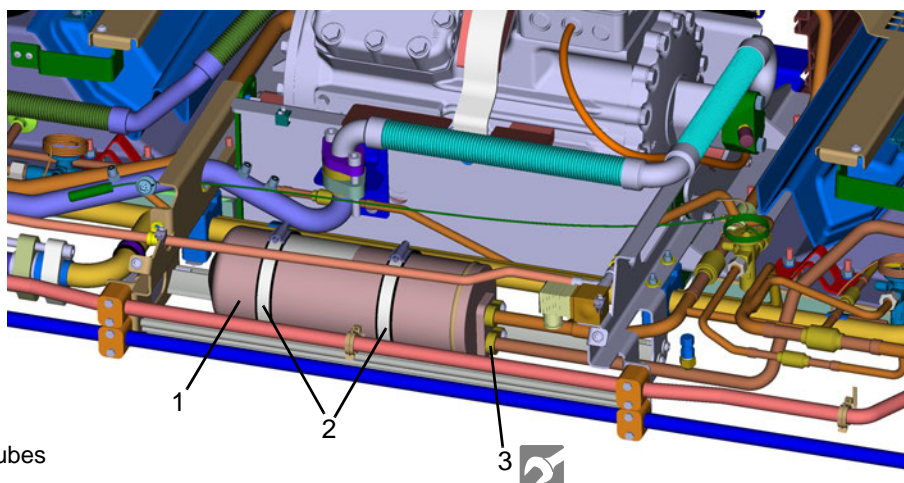

Fig. 905



## 9.7 Double radial blowers / axial fans removal/ installation

### 9.7.1 Remove a double radial blower

- Disconnect electrical connection to the housing (1, Fig. 906)
- Loosen side holders of the housing (2).
- Remove housing.

### 9.7.2 Install a double radial blower

- Insert housing (1) and orient.
- Attach holder (2) with screws.
- Reattach electric connection.
- Test functionality using SCT components test

### 9.7.3 Remove an axial fan

- Remove the electrical connection to the housing (4) from the holder (6).
- Remove attachment screws (5).
- Remove housing (4).

### 9.7.4 Install an axial fan

- Insert housing (4).
- Attach housing with attachment screws (5).
- Reattach electric connection and attach in holder (6).
- Test functionality using SCT components test

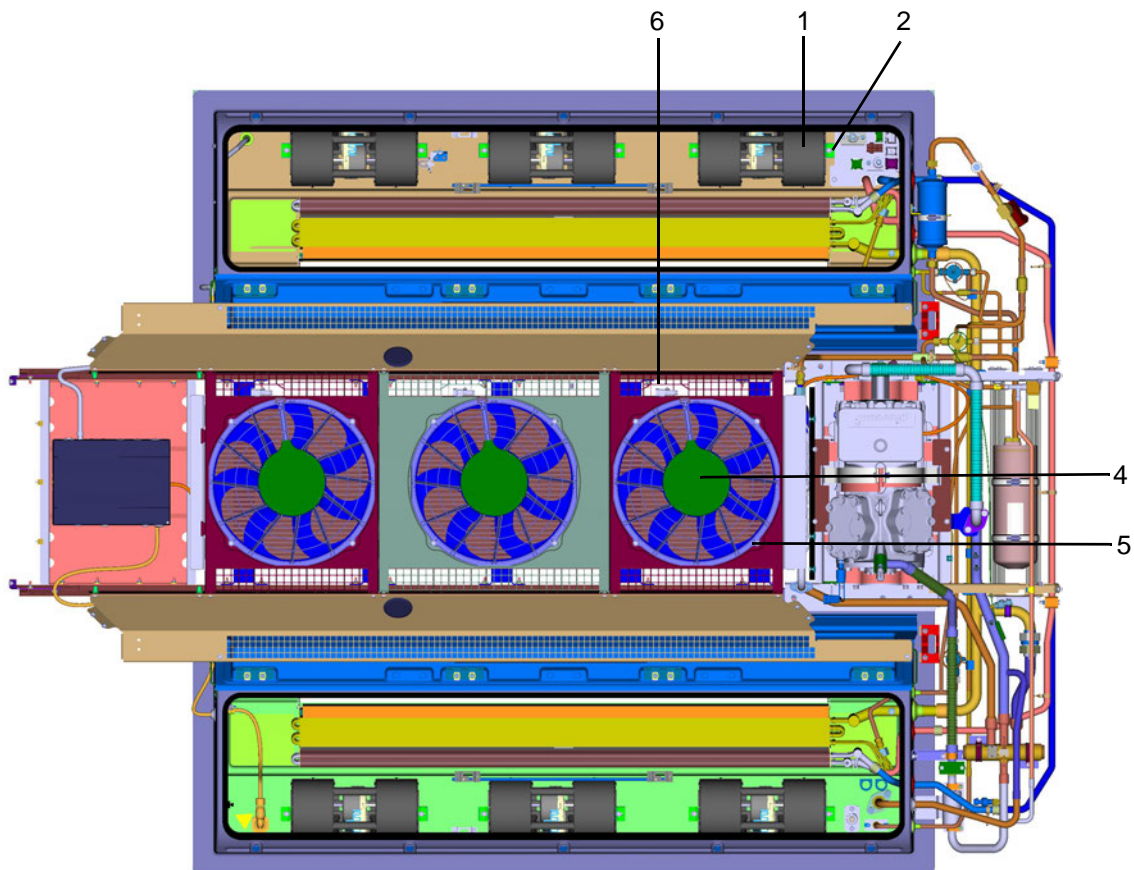

- 1 Double radial blower inner heat exchanger
- 2 Holder + screw double radial blower
- 3 Electric connection for double radial blower (no figure)

- 4 Axial fan outer heat exchanger
- 5 Attachment screws axial fan
- 6 Electrical connection axial fan in holder

Fig. 906

**9.8 Recirculating air flap actuator motor removal/ installation**

**9.8.1 Remove the actuator motor**

- Disconnect electric connection to the motor by removing the plug.
- Remove 3 nuts that were attached to damper motor and remove damper motor (1, Fig. 907).

**9.8.2 Install the actuator motor**

- Place the motor into the location of installation and attach with 3 nuts (1, Fig. 907).
- Reconnect electric connection to the motor / insert plug.

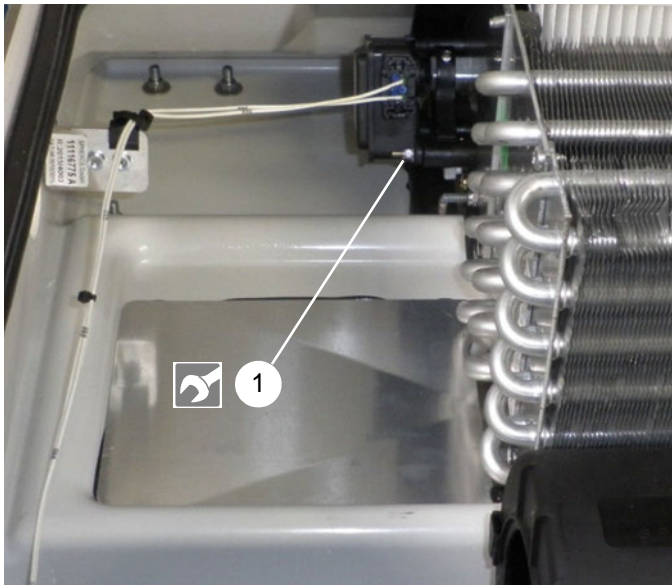

Fig. 907

**9.9 Temperature sensor (duct / recirculating air suction) removal/ installation**

Position: to the right side before the first double radial blower.

**9.9.1 Remove the duct temperature sensor (blow-out temperature)**

Position: to the right side before the first double radial blower (1, Fig. 908).

- Loosen electrical connection on the plug.
- Unscrew sensor from holder.

**9.9.2 Install the duct temperature sensor (blow-out temperature)**

- Screw sensor to holder.
- Reconnect electrical connection on the plug.

**9.9.3 Remove the recirculating air suction temperature sensor (passenger compartment)**

Position: in middle, right recirculating air suction inside of air-conditioning system (2, Fig. 908).

- Remove fresh air filter, see 7.4.1.
- Loosen electrical connection on the plug.
- Unscrew sensor from holder.

**9.9.4 Install the recirculating air suction temperature sensor (passenger compartment)**

- Screw sensor to holder.
- Reconnect electrical connection on the plug.
- Insert fresh air filter, see 7.4.1.

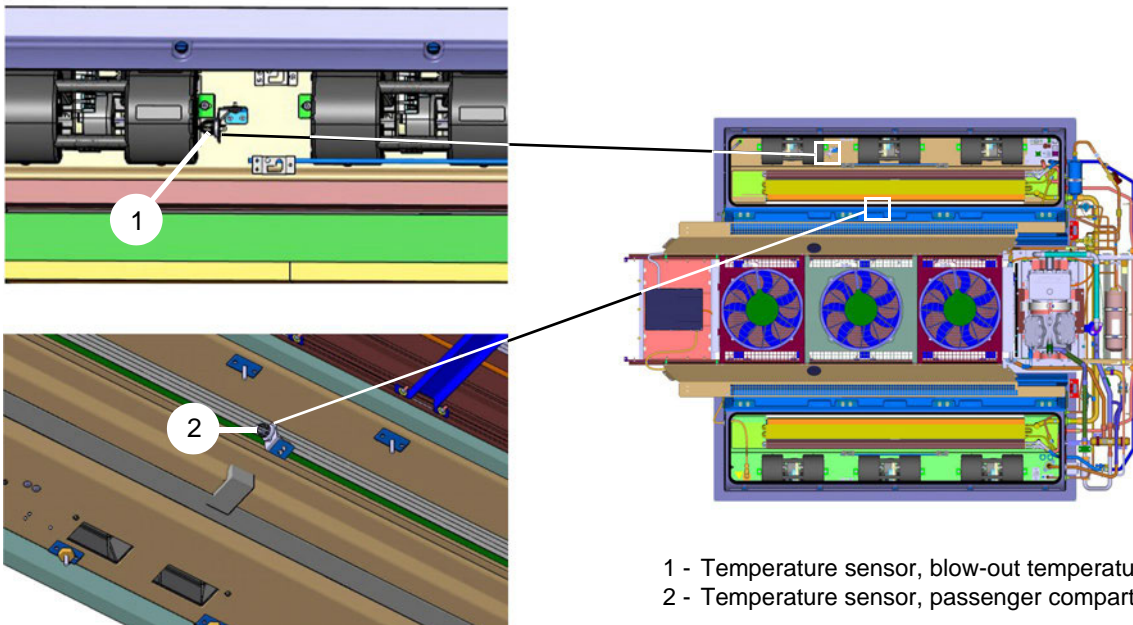

1 - Temperature sensor, blow-out temperature  
2 - Temperature sensor, passenger compartment

Fig. 908

### 9.10 Suction pressure sensor removal/ installation

There is a valve insert built into the soldering support of the suction pressure sensor (2, Fig. 909) that automatically closes when the sensor is removed from the support.

#### 9.10.1 Remove the suction pressure sensor

- Loosen electrical connection on the plug.
- Unscrew the sensor, holding the soldering support with a suitable tool.

#### 9.10.2 Install the suction pressure sensor

- Moisten sealing ring with refrigerator oil.
- Screw on the sensor, holding the soldering support with a suitable tool.
- Reconnect electrical connection on the plug.

#### ATTENTION:

The maximum pressure of the leak test is 17 bar, since otherwise the suction pressure sensor will become damaged!

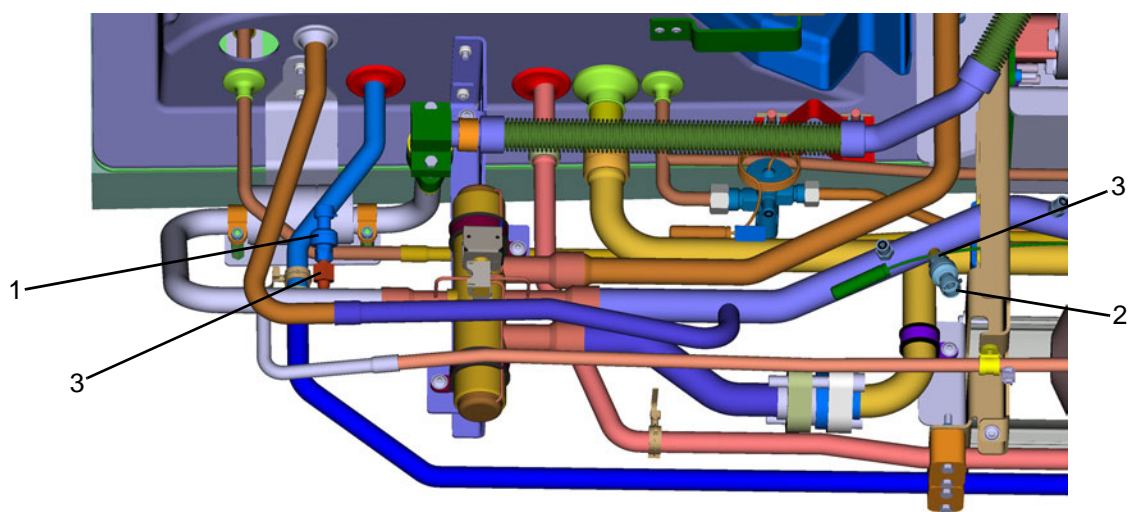

- 1 High-pressure sensor
- 2 Suction pressure sensor
- 2 Soldering support with valve insert

Fig. 909

### 9.11 High-pressure sensor removal/ installation

There is a valve insert built into the soldering support of the high-pressure sensor (1, Fig. 909) that automatically closes when the sensor is removed from the support.

#### 9.11.1 Remove the high-pressure sensor

- Loosen electrical connection on the plug.
- Unscrew the sensor, holding the soldering support with a suitable tool.

#### 9.11.2 Install the high-pressure sensor

- Moisten sealing ring with refrigerator oil.
- Screw on the sensor, holding the soldering support with a suitable tool.

- Reconnect electrical connection on the plug.

#### ATTENTION:

The maximum pressure of the leak test is 17 bar, since otherwise the suction pressure sensor will become damaged!



### 9.12 Pressure switch removal/ installation

There are valve inserts built into the screw neck of the pressure switch that automatically close when the sensor is removed from the support.

#### 9.12.1 Remove the pressure switch

- Disconnect electric connection.
- Unscrew pressure switch, holding onto the screw-in connector with suitable tool.

#### 9.12.2 Install the pressure switch

- Screw in new pressure switch with new copper sealing ring, holding onto screw-in connector with suitable tool.
- Reattach electric connection.
- Lay cable, making sure there are no points of abrasion.

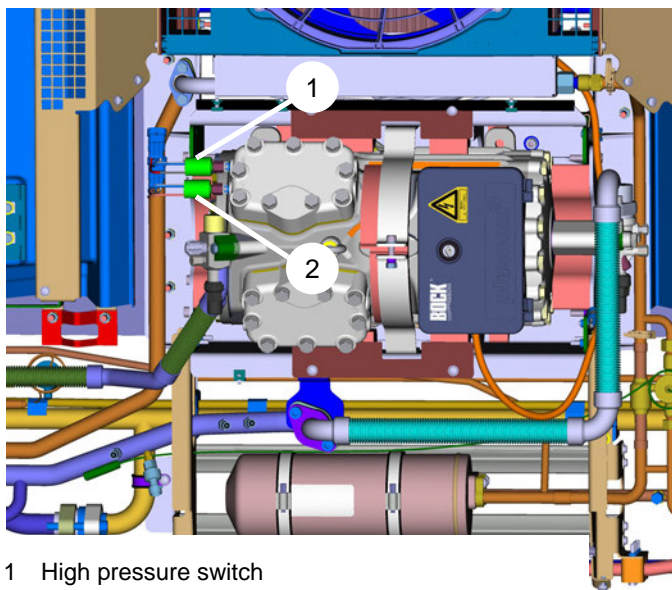

- 1 High pressure switch
- 2 Low pressure switch (not at 11123865\_)

Fig. 910

### 9.13 Compressor suction and pressure lines removal/ installation

#### 9.13.1 Remove the pressure line

- Conduct preparation work according to 9.3.
- Unscrew filler valve (2, Fig. 911) from the pressure line.
- Disconnect the pressure line at the SMA connection (3) from the 4-way valve.
- Disconnect the pressure line at the SMA connection from the compressor and remove pressure line.

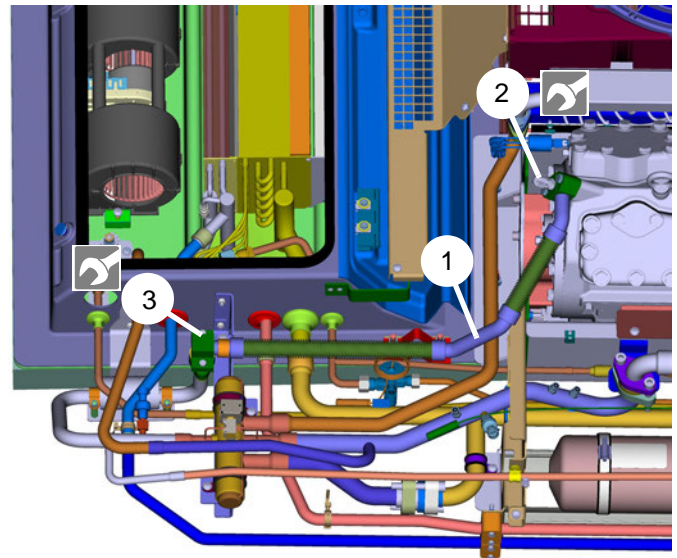

- 1 Pressurized gas line
- 2 Filler valve, pressure side
- 3 SMA connection pressurized gas line - 4-way valve

Fig. 911

#### 9.13.2 Install the pressure line

- Put pressure line including new seals (refrigerator oil applied) into installation position and align.
- Connect pressure line onto the compressor with SMA connection.
- Connect pressure line onto the 4-way valve with SMA connection (3).
- Screw filler valve (2, Fig. 911) into pressure line.
- Conduct follow-up work according to 9.3.

#### 9.13.3 Remove the suction line

- Conduct preparation work according to 9.3.
- Unscrew filler valve (2, Fig. 912) from the suction line.
- Separate connections of the suction line (1) and remove suction line.

#### 9.13.4 Install the suction line

- Put suction line (1) including new seals (refrigerator oil applied) into installation position and align.
- Connect both sides of the suction line.
- Screw filler valve (2) into the suction line.
- Conduct follow-up work according to 9.3.

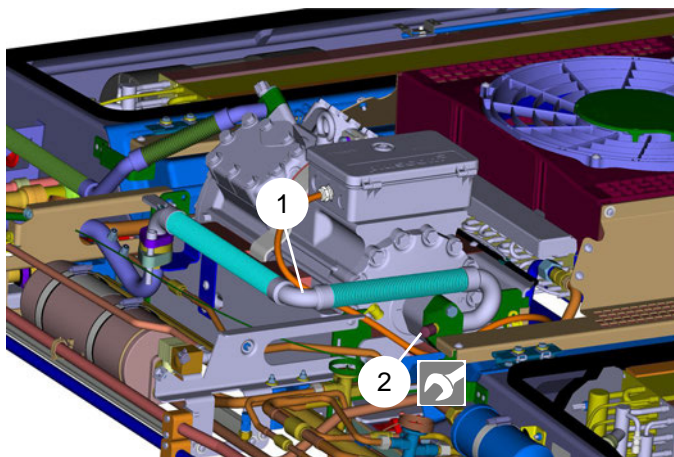

- 1 Suction line
- 2 Filler valve, suction side

Fig. 912

## 9.14 Solenoid valve removal/ installation

### 9.14.1 Remove the coil

- Unscrew knurled nuts (3, Fig. 913).
- Pull the coil (2) down.
- Pull out screw of the plug housing (4) and separate the housing from the coil.

### 9.14.2 Install the coil

- Plug the plug into coil (2) and attach with screw.

**NOTE:**

Verify seal fits correctly.

- Place coil (2) into position and secure with knurled nut (3).

**ATTENTION:**

Always ensure the plug points with the cable side down in order to avoid water entry into the plug!

### 9.14.3 Remove the screw-in valve

- Conduct preparation work according to 9.3.
- Remove coil, see 9.14.1.
- Loosen screw-in valve, attaching the housing with suitable tool.
- Remove screw-in valve.

### 9.14.4 Install the screw-in valve

- Screw on screw-in valve.
- Install coil, see 9.14.2.
- Conduct follow-up work according to 9.3.

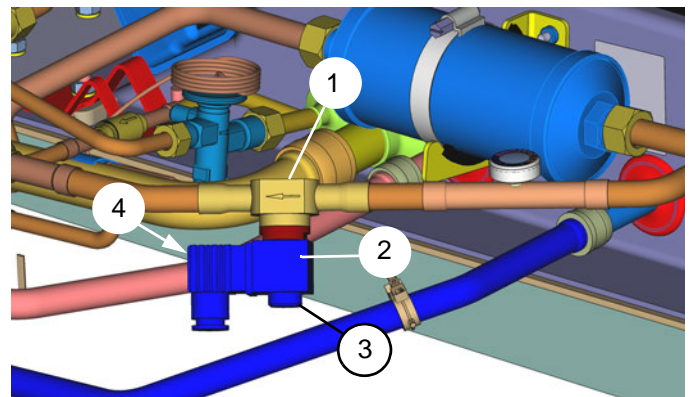

- 1 Solenoid valve with sight glass
- 2 Coil of solenoid valve
- 3 Knurled nut for coil
- 4 Screw for connector housing

Fig. 913



### Attachment A

#### Tightening torques / Sealings

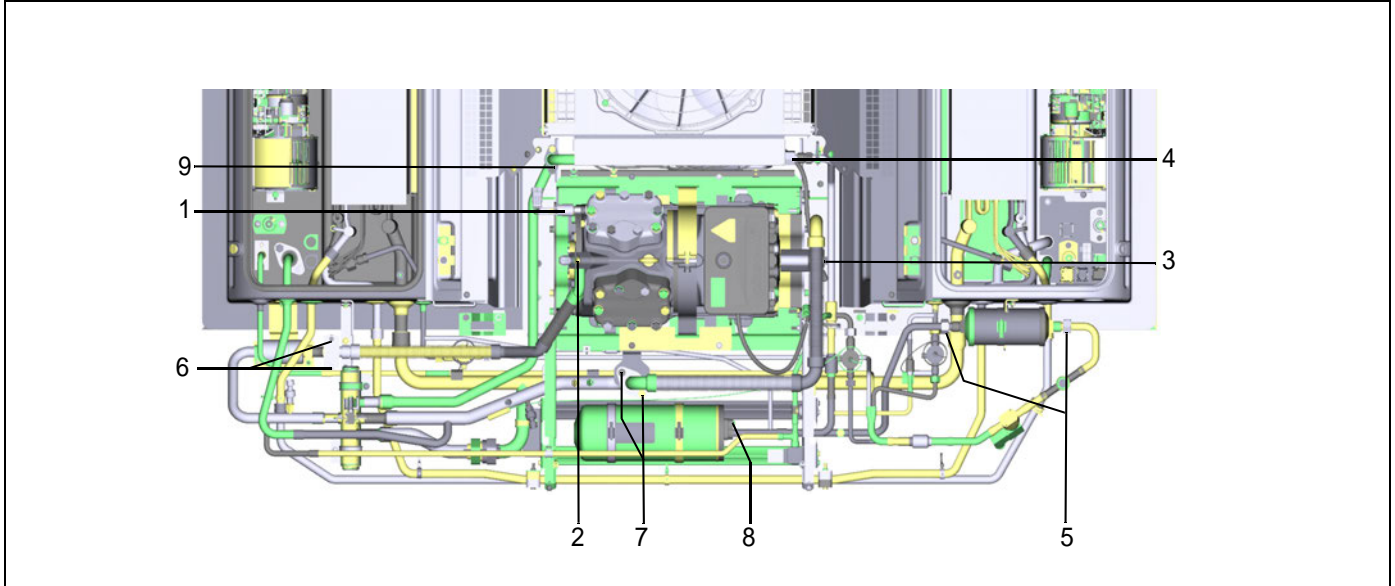

Item	Designation	Tightening torque in Nm	Sealing (R134a-resistant)	Valeo ID
1	union nut, pressure guard, low pressure guard (as per 11120816_) not shown	8 ± 10%	-	-
2	screw M8x50, pressure line compressor	34 ± 10%	flange seal oval	11117795A
3	screw M10x110, suction gas line compressor	50 ± 10%	flange seal oval	11117795A
4	union nut SW27, outer heat exchanger	25 ± 10%	O-ring 14 x 1,78	80641A
5	union nut SW27, filter drier	40 ± 10%	O-ring 14 x 1,78	80641A
6	screw M6x50	9 ± 10%	O-ring 26 x 2	69052A
7	nut M10, attachment suction gas line	25 ± 10%	flange seal round	24632A
8	SMA connection receiver	9 ± 10%	O-ring 11 x 2,5	11117038A
9	screw M8x50, outer heat exchanger	34 ± 10%	flange seal round	11121059A

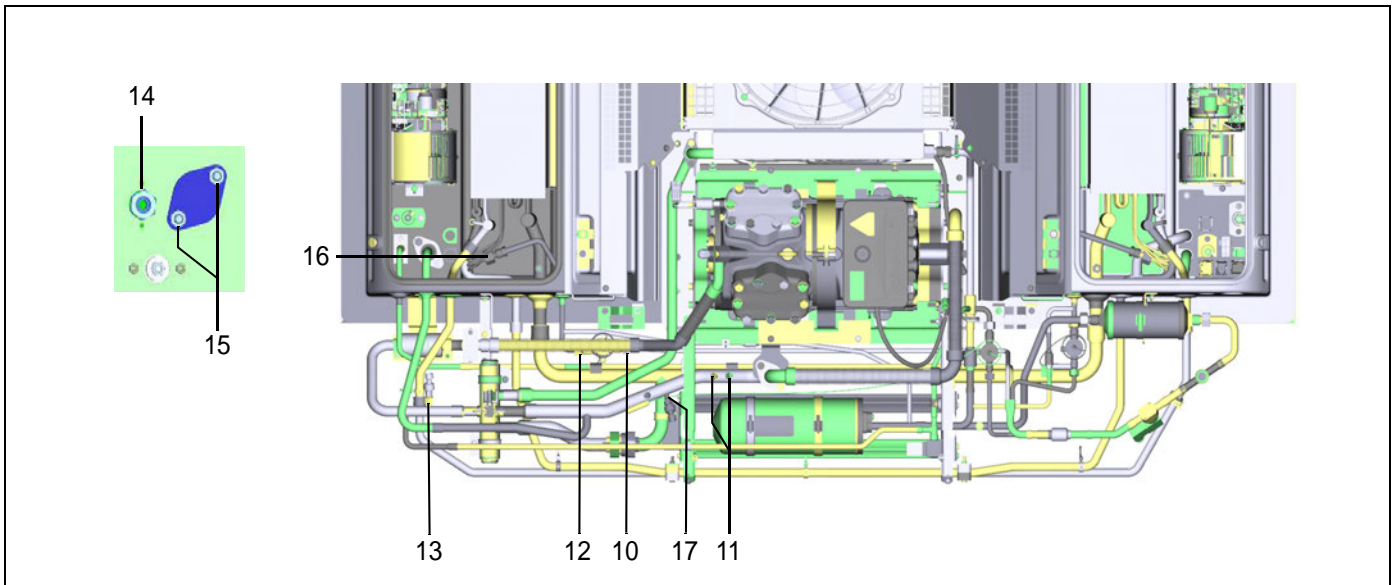

Item	Designation	Tightening torque in Nm	Sealing (R134a-resistant)	Valeo ID
10	union nut SW19, expansion valve inlet	17 ± 10%	O-ring 7,65 x 1,78	80812A
11	union nut SW17, expansion valve compensation line	10 ± 10%	O-ring 4,48 x 1,78	1103522B
12	union nut SW22, expansion valve outlet	25 ± 10%	O-ring 10,6 x 1,78	80640A
13	union nut SW14, sensor high pressure	10 ± 10%	O-ring 7,65 x 1,78	80812A
14	union nut SW27, liquid line front box	17 ± 10%	O-ring 14 x 1,78	80641A
15	nut M10, lid suction gas line front box	50 ± 10%	flange seal round	24632A
16	union nut SW27, inner heat exchanger	25 ± 10%	O-ring 10,6x1,78	80640A
17	union nut SW16, sensor suction pressure	10 ± 10%	-	-



